



Groupe de développement sportif / Sports Development Group

2023 ASN Canada

Race Regulations

Note: Regulations that are changed from the previous edition are indicated by a ***red, bold, italics font***.

These regulations govern all
National Series Competitions for 2023

Published by:

ASN Canada

200 circuit Gilles-Villeneuve,

Montréal, Québec, Canada, H3C 1A9

Phone: (514) 350-8203

Publication Date: **August 30, 2023**

ASN CANADA IS THE
GOVERNING BODY OF MOTORSPORT IN CANADA
APPOINTED BY
THE FEDERATION INTERNATIONALE DE L'AUTOMOBILE (FIA)

These regulations are intended to assist in the conduct of competitions and to further general safety.

They are a guide, and in no way a guarantee against injury or death to participants, spectators, or others.

No express or implied warranties of safety or fitness for a particular purpose shall be intended or result from publication of or compliance with these Regulations.

The contents of this book may be reproduced only with permission in writing from ASN CANADA.

ASN Canada
Groupe de développement sportif / Sports Development Group

President	François Dumontier
Vice President	Ron Fellows
Executive Director	Stephen Wetmore

**ASN CANADA
TERRITORIES AND AFFILIATES**

Atlantic Region Motor Sports (ARMS)
P.O. Box 38067 Burnside
Dartmouth, Nova Scotia, B3B 1X2
<http://www.armsinc.ca>

Canadian Association of Rallysport (CARS)
P.O. Box 300
Turner Valley, Alberta, T0L 2A0
Telephone: 1-855-640-6444
<https://carsrally.ca>

Confederation of Autosport Car Clubs (CACC)
18978 119 Ave
Pitt Meadows, BC
V3Y 1X6
<https://www.caccautosport.org>

CASC Ontario Region (CASC-OR)
7250 Keele Street
Suite 413
Concord, Ontario, L4K 1Z8
Telephone: 416-667-9500
Fax: 416-667-9555
<https://casc.on.ca>

Auto Sport Québec (ASQ)
9-4545 Pierre de Coubertin
Montréal, Québec, H1V 3R2
Telephone: 514-252-3052
<https://auto-sport-quebec.com>

Western Canada Motor Sport Association (WCMA)
P.O. Box 76002 RPO Southgate
Edmonton, Alberta, T6H 5V7
<http://www.wcma.ca>

DEFINITIONS TO BE USED

The following definitions are for use with these Regulations:

- ASN Canada** ASN Canada is used in these regulations for Groupe de développement sportif / Sports Development Group. ASN Canada is the national *sporting authority* for motorsports, nominated by the FIA.
- Associate Member:** Any body or person affiliated to ASN Canada by virtue of application and appointment. An Associate Member is a non-voting member.
- Closed Competition:** a competition confined solely to members and associate members of ASN Canada. A Professional Racing Authority Series is a Closed Competition.
- Competition:** a contest in which cars take part.
- Competitor:** a person who competes in an event as an entrant or driver.
- Entrant:** a licensed person or body entered for a competition.
- Event:** a program of competitors at a racetrack.
- Event Supplementary Regulations:** regulations that are presented by the Organizer of an event.
- FIA:** Fédération Internationale de l'Automobile.
- Finishing Line:** the last control line on a marked racetrack. The finish line may also be the starting line. The timing control line may be a different line.
- Force Majeure:** An event or effect that cannot be reasonably anticipated or controlled, or that restricts the ability to fully apply a Regulation.
- Marked Racetrack:** that portion of a racetrack that is used by cars for racing, and includes the paved surface, any curbing that exists, and the pit lane. On some tracks the primary racing surface is indicated by painted lines.
- National and National Series Competitions:** competitions including any Series competitions held in more than one Province of Canada (including Canadian events in the USA and USA events in Canada).
- Organizer:** a body authorized to organize an event by a permit obtained from ASN Canada or the Professional Racing Authority to hold an event.
- Organizing Permit:** the permit issued by the ASN Canada or the Professional Racing Authority to organize a single competition.
- Participant:** any person or body involved at an event as an official, entrant, driver, crew, or worker.
- Promoter:** any person or body (other than an Organizer) proposing to hold, or holding a series, event, or competition.
- Racetrack:** the entire property upon which a marked racetrack is situated.

Racetrack Licence: the licence for a racetrack issued by ASN Canada, and in some cases the FIA.

Registered Series Competitor: a competitor who has fulfilled all the requirements of ASN Canada and Professional Racing Authority and has been accepted for competition in a sanctioned Series.

Series Agreement: an agreement between ASN Canada and the promoter of a Series.

Series Director: a person, and any designates, authorized by a Series Promoter to represent the Series Promoter.

Starting Line: the control line on a marked racetrack and represents the point at which a race first commences. This line may also be the finishing line. The time control line may be an unmarked different line.

Table of Contents

1.	GENERAL	10
1.1.	Professional Racing Authority	10
1.2.	Sanctioning Authority	10
1.3.	Sanction for a Series.....	10
1.4.	ASN Competition Regulations.....	10
1.5.	Knowledge of Regulations	10
1.6.	Precedence of Regulation.....	11
1.7.	Licencing of Event Officials.....	11
1.8.	Authority of ASN Officials.....	11
1.9.	Calendar of Competitions	11
1.10.	Publications.....	12
2.	PARTICIPANT ELIGIBILITY	12
3.	ENTRANT'S LICENCE	12
4.	DRIVER'S COMPETITION LICENCE.....	12
4.2.	Minimum Age.....	13
4.3.	Assumed Names.....	13
4.4.	Medical Responsibility	13
4.5.	Physical Disabilities	13
4.6.	Refusal of Licence	14
4.7.	Validity of Licence.....	14
4.8.	Presentation of Licence	14
5.	ENTRANTS AND DRIVERS.....	14
5.1.	ASN Identification	14
5.2.	Conduct of Participants.....	14
5.3.	Alcoholic Beverages	15
5.4.	Narcotics and Drugs	15
5.5.	Submission to Testing.....	15
6.	ORGANIZATION OF NATIONAL COMPETITIONS	15
6.1.	Application for an Organizing Permit.....	15
6.2.	Conditions of Application	15
6.3.	Minimum Requirements to be Met.....	15
6.4.	Racetrack Licence	16
6.5.	Insurance Requirement.....	16
6.6.	Postponement/Cancellation	16
6.7.	Credentials for Officials.....	16
6.8.	Credentials for Series Promoters.....	16
6.9.	Notice on Official Documents.....	16
7.	REGULATION OF COMPETITIONS	16
7.1.	Series Race Director.....	16
7.2.	Steward(s)	17
7.3.	Clerk of the Course.....	18
7.4.	Chief Scrutineer	18
7.5.	Chief Starter.....	18
7.6.	<i>Chief Course Marshal</i>	18
7.7.	<i>Chief Pit Marshal</i>	18
7.8.	<i>Chief Medical Officer</i>	19
7.9.	<i>Chief of Timing and Scoring</i>	19
7.10.	Judges of Fact.....	19
7.11.	Competition Observers	19
8.	EVENT SUPPLEMENTARY REGULATIONS	20
8.1.	Contents of Regulations.....	20

8.2.	Minimum Age of Participation	20
8.3.	Unauthorized Practice	20
8.4.	Number of Starters	20
8.5.	Competitor Information	20
8.6.	Competitor Entry Form	20
8.7.	Required Indemnifications	21
8.8.	Refusal of Entries	21
8.9.	Falsification of Entry	21
8.10.	Conditional Acceptance of an Entry	21
8.11.	Status of an Accepted Entry	22
8.12.	Withdrawal of Entry	22
8.13.	Entering/Use of a Back-Up Car	22
8.14.	False Grid Equipment	22
8.15.	Race Starter's Equipment	22
8.16.	Flags and Signals	23
8.17.	Timing, Scoring, Results	23
8.18.	Race Length	23
8.19.	Race Winner	23
8.20.	Dead Heats	24
8.21.	Overall Race Finishers	24
8.22.	Class Finishers (Endurance Races)	24
8.23.	Crossing the Finish Line	24
8.24.	Weighing Scales	24
8.25.	Noise Level of Race Cars	25
9.	CONDUCT OF RACE EVENTS	25
9.1.	Instructions to Competitors	25
9.2.	Qualifying for a Race	25
9.3.	Starting Positions	25
9.4.	Layout of Starting Grids	26
9.5.	To Be Considered a Race Starter	26
9.6.	Racing Commences at the GREEN Flag	26
9.7.	Use of a Safety Car	26
9.8.	Stopping/Re-starting a Race	27
9.9.	Effect of Stopping a Race	27
9.10.	Re-Scheduling of a Competition	27
9.11.	Rain Race Procedure	28
9.12.	Impound Procedures	28
10.	ROLLING START PROCEDURES	28
11.	STANDING STARTS USING LIGHTS	29
12.	STANDING STARTS USING FLAGS	30
13.	STARTING LIGHT SYSTEMS	30
14.	FLAG SIGNALS	30
15.	COMPETITOR CONDUCT ON THE RACETRACK	32
15.1.	General	32
15.2.	Conduct During Race Starts	32
15.3.	Push-Starting a Car	32
15.4.	Conduct on the Racetrack	32
15.5.	Passing on the Racetrack	33
16.	RULES OF THE PITS	33
16.1.	General	33
16.2.	Pit Lane Speed Limit	34
16.3.	Pit Stops	34
16.4.	No Refuelling in Pit Lane	34
16.5.	Generators in the Pits	34
16.6.	Other Devices in the Pits	34

16.7.	Exiting the Pits	35
17.	REFUELLING (ENDURANCE RACES).....	35
17.1.	General	35
17.2.	Refuelling Personnel	35
18.	PADDOCK SAFETY	35
19.	OVAL TRACK RACES.....	35
20.	RACE CARS GENERAL.....	36
20.1.	General Safety Matters	36
20.2.	Technical and Safety Inspection	36
20.3.	Decals and Advertising	36
20.4.	Appearance of Cars	37
20.5.	Racing Numbers	37
20.6.	Race Car Technical Documentation	37
20.7.	Measurement of Cars/Components	38
20.8.	Race Car Weights.....	38
20.9.	Engine Fuel to be Used	38
20.10.	Race Tires	38
21.	IN-CAR CAMERAS/RADIOS	38
22.	SEALED COMPONENTS	39
23.	PRODUCTION-BASED or HOMOLOGATED SERIES CARS	39
23.1.	General	39
23.2.	Required Modifications	39
23.3.	Allowable Modifications.....	40
23.4.	Restrictions	40
23.5.	Series Cars on Public Roads	40
24.	ENDURANCE RACING REFUELLING EQUIPMENT	40
25.	FIRE EXTINGUISHERS	41
25.1.	Extinguisher Systems	41
25.2.	General	42
25.3.	Hand-Held Extinguishers	42
25.4.	Plumbed-In Extinguishers	42
25.5.	Method of Operation	42
25.6.	Weight Checking.....	42
25.7.	Installation.....	42
26.	DRIVER SAFETY SYSTEM	43
26.1.	Driver's Equipment.....	43
27.	DRIVER RESTRAINT SYSTEM	44
28.	CLOSED WHEEL ROLL CAGE CONSTRUCTION	46
28.1.	General Description For Removable and Non-Removable Structures.....	46
28.2.	Bolt Specification	47
28.3.	Tubing Material and Sizes	47
28.4.	Main Roll Hoop	47
28.5.	Front Roll Hoop.....	47
28.6.	Bracing.....	48
28.7.	Side Protection.....	48
28.8.	Mounting Plates	49
28.9.	Seat Back Mounting.....	49
28.10.	Recommended tubing attachment methods:	49

29.	OPEN WHEEL ROLL PROTECTION INSTALLATION	50
29.1.	Main Roll Hoop Bracing	51
29.2.	Front Roll Hoop Bracing.....	51
30.	VIOLATION OF REGULATIONS.....	51
30.1.	Assessment of Penalties.....	51
30.2.	Breach of Regulations	51
30.3.	Repeated Violations.....	52
31.	PENALTIES.....	52
31.1.	Reprimand	52
31.2.	Time Penalty.....	52
31.3.	Distance Penalty.....	52
31.4.	Monetary Fine.....	52
31.5.	Exclusion Penalty	52
31.6.	Amendment of Placing.....	52
31.7.	Loss of Event Awards	52
31.8.	Loss of Series Points	52
31.9.	Disciplinary Action	52
31.10.	Probation	52
31.11.	Suspension of Privileges.....	53
31.12.	Disqualification.....	53
31.13.	Publication of Penalties	53
32.	PROTESTS	53
32.1.	The Right Of Protest	53
32.2.	Time Limits for Protests	54
32.3.	Eligibility of a Race Car.....	54
32.4.	On-Track Conduct	54
32.5.	Results.....	54
32.6.	Video Evidence	54
32.7.	Protest of a Race Car	55
32.8.	Lodging a Protest.....	55
32.9.	Hearing of a Protest.....	55
32.10.	Distribution of Awards.....	56
32.11.	Judgement from a Protest Hearing	56
32.12.	Protest Fees	56
32.13.	Publication of Judgements.....	56
33.	APPEALS	56
33.1.	Request for an Appeal	56
33.2.	Grounds for Appeal Requests.....	56
33.3.	Time Limit	56
33.4.	Effect of Requesting an Appeal	57
33.5.	Required Submissions.....	57
33.6.	Decision to Grant an Appeal	57
33.7.	Appeal Proceedings.....	57
33.8.	Provision for Expedited Appeal.....	58
33.9.	Jurisdiction of Appeal Proceedings.....	58
33.10.	Judgement of Appeal Proceedings.....	58
33.11.	Judgement is Final.....	58
33.12.	Publication of Judgements.....	58
33.13.	Conduct After Judgement	58

1. GENERAL

1.1. Professional Racing Authority

- 1.1.1. Groupe de développement sportif / Sports Development Group is referred to herein as "ASN Canada".
- 1.1.2. ASN Canada has drawn up these Regulations referred to herein as "these Regulations".
- 1.1.3. ASN Canada is the sole regulatory authority and shall render all decisions concerning these Regulations; determine eligibility for participation in competitions; appoint Officials; issue and withdraw licences; apply penalties for violation of these Regulations; do all things deemed in its judgement to be in the best interests of the conduct of motorsport.

1.2. Sanctioning Authority

- 1.2.1. Sanction for the establishment of a National Competition or National Series and individual events forming a Series is granted only by ASN Canada.

1.2.1.1. Sanctioning for regional series and events is the authority of the region in which the series operates.

- 1.2.2. ASN Canada shall sanction any Series event held outside of Canada and ASN Canada shall regulate such competitions in conjunction with the subject country's National Sporting Authority, or its designate.
- 1.2.3. ASN Canada shall sanction any Event held within Canada that forms part of a Series approved by another country's ASN or its delegate and shall co-operate with the event administrators regarding sporting regulation.

1.3. Sanction for a Series

- 1.3.1. To receive sanction to promote an ASN National Competition or Series, a promoter must make written application to ASN Canada documenting in detail all the administrative, technical, and financial particulars of the proposed National Competition or Series, be able to demonstrate overall financial responsibility, and set forth any proposed special requirements for the eligibility and conduct of the entrant, driver, or car, and be prepared to enter into formal agreement with ASN Canada.
- 1.3.2. ASN Canada reserves the right to refuse sanction of a proposed Series without stating the reason.

1.4. ASN Competition Regulations

- 1.4.1. The headings used in these Regulations are not to be read into the Regulations.
- 1.4.2. ASN Canada reserves the right to alter these Regulations at any time.
- 1.4.3. ASN Canada bulletins become part of these Regulations.
- 1.4.4. Each **National** Series shall draft their own Series Regulations which shall be submitted to ASN Canada for approval.
- 1.4.5. Each organizer shall draft Event Supplementary Regulations that **must** be submitted to **the sanctioning body** for approval.
- 1.4.6. These Regulations have been prepared in English text which shall prevail in terms of meaning and intent.

1.5. Knowledge of Regulations

- 1.5.1. Every person, body, group of persons, etc., promoting a Series; organizing a competition or event or take part therein; or by and upon applying for an agreement, sanction or permit or license of any kind from ASN Canada; by and upon participation at a competition as an entrant, driver or otherwise shall by doing so be deemed to and recognize that:
 - a. They have acquainted themselves with these Regulations.
 - b. They have submitted themselves without reservation to the consequences resulting from the application of these Regulations.
 - c. Have renounced, under pain of disqualification, the right to have recourse to any arbitrator or judicial tribunal not provided for in these Regulations.

- d. Have agreed to exonerate and keep indemnified all bodies; sponsors and their agents, race track owners, race organizers and their officials and agents, ASN Canada and its directors, officers, officials and its subsidiaries, agents and associate members, from and against all liability whatsoever to any such person or body or group of persons respectively in respect of, or in connection with any meeting, competition, or event held under these Regulations, from whatever cause arising or alleged to arise and notwithstanding that the same may have been contributed to, or occasioned by, the negligence of the said bodies, their agents, officials, servants, or representatives.
- e. In the case of entrants for, and drivers in, events, have agreed in the circumstances (aforesaid in 1.5.1d) to exonerate and keep indemnified all and any other competitors, their servants, and agents, from and against any liability whatsoever, including direct liability, to such entrants or drivers in connection with the driving of cars or any other act, omission, or occurrence during the course of a competition or official practice.
- f. Have agreed as set out in Sections 1.5.1d and 1.5.1e of this Regulation with each and all the persons and bodies referred to in those Sections and so that each and any of those persons or bodies shall be entitled to the benefit of such agreements.

1.5.2. Acknowledgment of Rules

Every driver, entrant, official, promoter or other participant in an ASN Canada-sanctioned event, and every person who is issued an ASN Canada licence agrees, without reservation, to conduct themselves in accordance with these ASN Canada Regulations.

In case of a disagreement or dispute regarding the meaning or application of these ASN Canada Regulations, the interpretation and application by ASN Canada officials present at the event shall prevail.

In order to promote the sport of auto racing and to achieve prompt finality in competition results, all ASN members and licence holders expressly agree that decisions by ASN Canada officials as to the applicability and interpretation of these Regulations are not subject to litigation.

ASN Canada members and licence holders covenant that they will not initiate or maintain litigation of any kind against ASN Canada or anyone acting on behalf of ASN Canada, with the intention of reversing, modifying, or obtaining relief from such decisions.

If a member or licence holder initiates or maintains litigation in violation of this covenant, the member or licence holder agrees to reimburse ASN Canada for the costs of such litigation, including attorney's fees.

1.6. Precedence of Regulation

The precedence of Regulations shall be as follows:

- a. **ASN Canada** Regulations.
- b. ASN **Canada** Bulletins.
- c. Series **or Regional** Regulations.
- d. Series or Regional Bulletins.**
- e. Event Supplementary Regulations.
- f. Instructions from **sanctioned** Officials; **series officials for series entrants, event officials for all other participants.**

1.7. Licensing of Event Officials

For an ASN Canada sanctioned series the Race Director, Steward(s), Chief Scrutineers, **the series** Chief of Timing & Scoring and Chief Pit **Official** must possess a valid ASN Officials licence. **For events with ASN Canada sanctioned series**, the Clerk of the Course, Deputy Clerk of the Course, Chief Starter, Chief Course Marshal, Chief Pit Marshal, and the Chief Medical Officer must possess a valid ASN Officials licence.

1.8. Authority of ASN Officials

- 1.8.1. ASN Canada licenses the officials listed in Section 1.7, their respective assistants, and other officials as necessary.
- 1.8.2. The Race Director is responsible for the safe conduct of an event. See Section 7.1 for more details.
- 1.8.3. The Series Steward(s) have complete authority for the enforcement of these Regulations, Series Regulations, and Event Supplementary Regulations as they may affect Series sporting matters. See Section 7.2 for more details.

1.9. Calendar of Competitions

ASN Canada shall publish an annual calendar of competitions.

1.10. Publications

- 1.10.1. Publications made by promoters, sponsors, and organizers, in connection with or resulting from Series competitions shall be produced in accordance with the laws of the land, be in good taste, and shall not be misleading or untruthful.
- 1.10.2. Publications under these Regulations means; radio and television productions and promotional videos; printed advertisements, brochures, booklets, forms; signs, or displays.
- 1.10.3. Publications shall include the logo of ASN Canada and the wording, "Sanctioned by ASN Canada".
- 1.10.4. Results of a competition published prior to the issuance of official results by the Series or ASN Canada shall contain the words "Provisional".
- 1.10.5. Competitors who allow their names, photographs, or likeness to be used in connection with misleading advertising shall be subject to disciplinary action.
- 1.10.6. Promoters and organizers shall co-operate in making available to ASN Canada any photographs, film, or video recording of a competition for sporting administration purposes by ASN Canada.

2. PARTICIPANT ELIGIBILITY

2.1.1. Organizers

Application for a permit to organize competitions that are part of an ASN Canada Series is restricted to parties approved by ASN Canada and who are associate members of ASN Canada.

2.1.2. Entrants

An entrant in an individual Series competition who is not the nominated driver must possess an Entrant's Licence granted by ASN Canada, an Entrant automatically becomes an associate member.

2.1.3. Drivers

Participation in a Series competition by a driver is restricted to drivers who are associate members of ASN Canada. By and upon receipt of a valid ASN Canada driver's competition licence, a driver automatically becomes an associate member.

3. ENTRANT'S LICENCE

An Entrant's Licence is a privilege and not a right. An Entrant's licence granted by ASN Canada may be withdrawn by ASN Canada at any time.

4. DRIVER'S COMPETITION LICENCE

- 4.1.1. The holding of a driver's competition licence is a privilege and not a right. It is a privilege granted to an individual by ASN Canada. A driver's competition licence may be withdrawn or suspended by ASN Canada at any time.
- 4.1.2. To be eligible to compete in an ASN Canada sanctioned Series, a driver must possess a valid:
 - a. FIA International competition licence or,
 - b. ASN Canada National Competition licence or,
 - c. National licence as issued by an ACCUS-affiliated organization such as IMSA, Indycar, NASCAR, USAC, or
 - d. Sports Car Club of America (SCCA) Professional competition licence.
 - e. On application, a Nationally sanctioned series may accept the entry of a Driver with a current Regional 'A' Licence issued by an ASN Canada-affiliated region.

- 4.1.3. Drivers granted an FIA International competition licence by a foreign ASN must possess a letter of authority from their ASN giving permission to race in Canada and must possess an International Medical Card (available from their ASN). Such drivers must apply for and receive Associate Membership in ASN Canada and pay a fee of \$50 + GST.
- 4.1.4. Other ACCUS-affiliated licence holders, (as defined in Section 4.1.2) above), must obtain Associate Membership in ASN Canada and pay a fee of \$50 + GST.

4.2. Minimum Age

The minimum for issuance of any competition licence is 16 (sixteen) years of age.

4.2.1. *A derogation to a 15-year-old applicant would be considered under the following:*

- a. *Having reached 15 years of age at the time of the first event they wish to participate.***
- b. *A record of their racing experience.***
- c. *A letter of recommendation from a GDS/ASN appointed instructor or senior official.***
- d. *To be under observation by the Event Officials during the period between the issuing of the license and the time they reach 16 years of age.***
- e. *Any decision from an event official to stop the competitor from participating in any free practice, qualifying or a race is not subject to protest or appeal.***

- 4.2.2. ***If successful, applicants under the age of 16 may be issued a Race licence which makes them eligible to compete in F1200, F1600, or equivalents of no greater performance or closed wheel cars equal to or less than 2000 cc which are naturally aspirated.***

4.3. Assumed Names

No entrant, driver or crew member shall enter an event or sign the waiver and release with an assumed or fictitious name unless first authorized in writing by ASN Canada. The use of an assumed or fictitious name shall not relieve the individual of any obligations, liabilities, or penalties under these Regulations or those of a Series or Event.

4.4. Medical Responsibility

- 4.4.1. Drivers shall not participate in any competition unless they meet, and continue to meet, the medical requirements of the competition licence held.
- 4.4.2. Drivers shall submit the report of a medical examination, performed by a licensed medical practitioner, at the time of initial application for a driver's competition licence. Medical examination reports must be submitted every second year thereafter excepting:
 - a. Holders of FIA International A, B, and C licences require an annual medical examination and certification,
 - b. Drivers 40 years of age and over require an annual medical examination and certification.

The medical reports must certify the applicant to be medically fit to drive a car in speed events.

- 4.4.3. All examinations must be completed by a licensed medical practitioner doctor using only an ASN Canada approved medical form. ASN Canada reserves the right to refer any submitted medical form to a licensed medical practitioner of its choice for review.
- 4.4.4. Any licence holder who suffers injury or illness, at any time, that may impair or prejudice in any way the holder's ability to drive a car in speed events shall report such injury or illness immediately to ASN Canada and submit to a medical examination and be re-certified fit for competition before again competing.
- 4.4.5. After any accident during competition, it is mandatory for any involved driver to report to the event Medical Officer and to submit to any examination deemed necessary for purposes of determining fitness to resume competition.
- 4.4.6. Failure of a driver to submit to a medical examination will result in a penalty that may include exclusion from the competition without recourse to protest or appeal.
- 4.4.7. A decision made by an Event Medical Officer regarding the fitness of a driver for competition is final and not subject to protest or appeal.

4.5. Physical Disabilities

- 4.5.1. A driver shall not be issued a competition licence when he or she is known or suspected to be suffering from any illness or disability deemed to be incompatible with the fitness required for racing, including, but not limited to, those listed below:
- a. Monocular vision.
 - b. Colour blindness that would impair the ability to distinguish the exact colours of flags or lights.
 - c. Epilepsy, under treatment or not, with clinical manifestations confirmed during the 10 previous years.
 - d. In principle, the use of orthopedic devices, unless the functional result is equal or near to normal.
 - e. Amputations of fingers, except in those cases where the gripping function of the hands is unimpaired.
 - f. Any cardiovascular problem with a risk of sudden death.
 - g. Any other physical or psychological disabilities, temporary or permanent, that by their nature in the opinion of a competition knowledgeable medical practitioner, would render the individual unfit for competition.
 - h. Individual Determinations - In the event of a licence applicant not being recommended for a competition licence by a medical practitioner, an individual may apply to ASN Canada for an Individual Determination Assessment by an ASN Canada-appointed licensed medical practitioner. Results from an assessment are final and binding on the applicant. The applicant will be responsible for any costs involved in an assessment.
- 4.5.2. A driver may be issued a competition licence with the following illnesses or disabilities, upon review by ASN:
- a. Diabetes being treated with insulin or sulfonylureas.
 - b. All psychological conditions including Attention Deficit Hyperactivity Disorder (ADHD).
 - c. Any health problem that might, because of its nature or the treatment required, result in consequences that are harmful to participation in motorsport including in case of an accident.
- 4.5.3. Should a Medical Officer at a competition, upon examination of a competitor, deem a competitor unfit for competition, even temporarily, the competitor shall abide by the decision of the Medical Officer. No protest or appeal is allowed in this regard.

4.6. Refusal of Licence

ASN Canada reserves the right of refusal to issue a licence without stating the reason for such refusal.

4.7. Validity of Licence

- 4.7.1. Canadian competitors must hold a licence issued by ASN Canada. Another ASN may issue a licence to a Canadian only after receiving written authorization to do so from ASN Canada.
- 4.7.2. ASN Canada may not issue International Licences to non-Canadians without first obtaining written authorization from the ASN of that person's country of citizenship to do so.
- 4.7.3. A licence granted by ASN Canada does not constitute a certificate of competency of the holder.
- 4.7.4. Licences shall be valid from the date of issue to December 31 of the same year.

4.8. Presentation of Licence

Entrants and drivers must present their licences to an official when requested.

5. ENTRANTS AND DRIVERS

5.1. ASN Identification

Drivers shall wear at all times an ASN Canada identity patch on the front of the driver's suit above the waist.

5.2. Conduct of Participants

- 5.2.1. Participants in an ASN Canada sanctioned competition shall conduct themselves according to the highest standards of behaviour and sportsmanship, particularly in relations with other competitors, officials, sponsors, and their products, and in manner that shall not be prejudicial to the reputation of ASN Canada, promoters, sponsors, organizers, or to motorsport in general. Failure to do so may result in penalties.
- 5.2.2. Entrants and drivers are responsible for the conduct of their crew members and guests. A violation of these Regulations committed by an entrant, driver, crew member or guest may be directly chargeable to the driver and result in penalties that may ultimately affect the outcome of a competition.

5.3. Alcoholic Beverages

Participants at an event shall not consume alcoholic beverages during the performance of their duties at the racetrack. Any action taken, or penalty applied by the Steward(s) in this regard is not subject to appeal.

5.4. Narcotics and Drugs

The use of any narcotic or illegal substance, as defined in law, or the improper use of legal substances, by any participant is prohibited. The Steward(s) may prohibit participation if it is suspected that any substance has been consumed. Such action is not subject to appeal.

5.5. Submission to Testing

ASN Canada reserves the right to require any participant to submit to and complete; breath, blood, urine, or other tests designed to determine the presence of alcohol, narcotics, dangerous drugs, illegal substances, or the inappropriate use of legal substances. Such action is not subject to appeal.

6. ORGANIZATION OF *NATIONAL* COMPETITIONS

6.1. Application for an Organizing Permit

- 6.1.1. The Series Director shall apply to ASN Canada for a Series to be Sanctioned, which will include all the scheduled events in the series.
- 6.1.2. To conduct a competition, application must be made in writing to ASN Canada a minimum of 12 weeks prior to the first scheduled event. Applicants must enclose the appropriate fee. Late applications are subject to penalty.
- 6.1.3. A competition shall not be held until ASN Canada has granted an organizing permit and has received payment. ASN Canada may attach conditions to the granting of a permit, decline to grant a permit, or withdraw a permit without stating any reason.
- 6.1.4. An application from an Organizer or Series Director which has failed to discharge any requirements or any indebtedness to ASN Canada in respect of previous events will not be approved.

6.2. Conditions of Application

An application to organize a Series must include at least the following:

- The applicant's name, address, and telephone number,
- The nature, place, and dates of the competitions,
- The Series Regulations and the Event Supplementary Regulations if available,
- A list of the officials licensed by ASN Canada,
- Each event organizer shall provide to the Series Director details describing:
 - ⇒ Equipment at each track signaling post,
 - ⇒ Name of doctor(s),
 - ⇒ Description of the medical staff,
 - ⇒ Ambulance provisions,
 - ⇒ Tow trucks,
 - ⇒ Mobile fire-fighting equipment,
 - ⇒ Driver rescue (extrication) equipment,
 - ⇒ Provisions for spectator first-aid,
 - ⇒ Name of the hospital(s) to be used.

6.3. Minimum Requirements to be Met

An organizer shall meet the following minimum requirements any time a track session is in progress. Activities shall be halted by the Race Director unless the minimums are met and maintained:

- 6.3.1. One medical doctor with life-support training and equipment, and one registered nurse, (non-participants in the event) both available and equipped to respond to an on-track emergency.
- 6.3.2. Alternatively, the nurse may be substituted by a second doctor or, where Provincial regulations allow, a paramedic or EMT, trained in, and equipped for, life support procedures.
- 6.3.3. An ambulance equipped for Advanced Life Support (ALS), licensed by the Provincial government for use as an emergency ambulance and staffed by provincially licensed attendants.
- 6.3.4. No less than one 10-pound dry chemical fire extinguisher for every 15 metres of pit length.

6.4. Racetrack Licence

An organizing permit shall be issued only when the racetrack to be used is in possession of a Racetrack Licence issued by ASN Canada, an ASN Canada-affiliated region, or the FIA, or in cases of competitions held outside Canada, a Racetrack Licence issued by that country's ASN, or its designate.

The Racetrack Licence must be displayed in Race Control.

6.5. Insurance Requirement

ASN Canada requires that all events be insured for Liability and Participant Accident in coverage and amounts established by ASN Canada.

The following are the minimum insurance requirements for any event at which races sanctioned by ASN Canada form part of the program:

Category	Minimum Coverage
Spectator Liability	\$ 5,000,000
Participant Legal Liability	\$ 5,000,000

6.6. Postponement/Cancellation

- 6.6.1. Once an organizing permit has been issued, a competition shall not be postponed, abandoned, or cancelled prior to its scheduled start unless ASN Canada so orders for reasons of safety or force majeure.
- 6.6.2. If an entire event is cancelled prior to its commencement, the Organizer shall make reasonable efforts to notify all entrants, but neither the organizer, the Series promoter or ASN Canada shall accept any responsibility for any matters arising from the cancellation. Entry fees shall be returned to those not offered any opportunity to use the marked race track.

6.7. Credentials for Officials

- 6.7.1. Organizers shall recognize **Series** officials and their assistants, vehicles and equipment, competition observers equivalent to one per designated flag station, and provide credentials and passes necessary to perform their functions.
- 6.7.2. Organizers shall assure access by **Series** Officials to the Race Control centre during the running of Series races.

6.8. Credentials for Series Promoters

Organizers, as a condition of the granting of an Organizing Permit, shall recognize the Series promoter representatives and their supplier representatives, and provide the necessary credentials and passes for a reasonable number of personnel and equipment for purposes of administering their Series.

6.9. Notice on Official Documents

All Supplementary Regulations, programs, entry forms, and results relating to any ASN Canada competition shall bear in a conspicuous manner the logo of ASN Canada as well as the following announcement: "Sanctioned by ASN Canada".

7. REGULATION OF COMPETITIONS

7.1. Series Race Director

- 7.1.1. The Race Director shall be responsible for the general conduct of all sporting aspects of ASN Canada Series competitions at an event and to ensure conformity with all provisions of these Regulations and relevant Series and Event Supplementary Regulations and in addition shall:
- a. Control of all on-track sessions including practice, qualifying and races, adherence to the timetable, and if necessary, making any proposals for changes to the Steward(s).
 - b. Have the authority to stop practice, qualifying or race sessions if they deem it unsafe to continue.
 - c. Ensure the correct start and restart procedures are followed.
 - d. Control the use of the Full Course Yellow and Safety Car (neutralizing the race).
 - e. Report any alleged breaches of the Regulations to the Steward(s).
 - f. Replace an official unable to perform their duties.
 - g. Assign certain responsibilities and authorities to other officials.
 - h. If there are no Series Stewards, the Race Director will also hold the duties and authorities otherwise invested in the Stewards.

7.1.2. For Regionally sanctioned series, the role, duties, and authorities of Race Director, except for 7.1.1h, shall be delegated to the Clerk of the Course.

7.2. Steward(s)

- 7.2.1. The Steward(s) shall have supreme authority for the enforcement of these Regulations and relevant Series and Event Supplementary Regulations and within the framework of their duties, they:
- a. May prevent an ineligible driver or car from participating.
 - b. May prohibit from competing, any driver or car considered dangerous.
 - c. May exclude from the competition any entrant, driver, crew member or Series official found guilty of misbehaviour, unfair practice or who refuses to obey the order of a race official.
 - d. May authorize a change of driver or car.
 - e. May authorize a change in the programme where such a change affects a Series.
 - f. May authorize the alteration of composition or the consolidation of heats.
 - g. May authorize the modification of the race start procedures and/or finish line.
 - h. May authorize amendments to the Schedule for reasons of force majeure or safety including the postponement, abandonment, or stoppage of a competition.
 - i. May authorize amendments to the Supplementary Regulations.
 - j. May order the amendment of the results of a competition to take into account a time or distance penalty or the exclusion of a competitor.
 - k. May apply penalties for breaches of these Regulations, Series Regulations and Event Supplementary Regulations, including the suspension of any assessed penalties.
 - l. May declare the classifications and results to be final after all technical checks have completed and the expiration of the protest period.
 - m. May order technical checks to be carried out.
 - n. May require that alcohol testing be carried out, at the request of ASN Canada or on their own initiative.
 - o. May prohibit from participation any competitor or entrant suspected of using any narcotic or illegal substance, as defined by law, or the improper use of a legal substance.
 - p. May apply penalties as necessary arising from protests, appeals and disciplinary hearings.
 - q. May suspend part or all of an assessed penalty.
 - r. May order the removal and/or eject a person from all or part of the Reserved Areas of an Event and/or deny a person any further access to the same, at the request of **the sanctioning body** or on their own initiative.
 - s. Where required, will send a closing report to **the sanctioning body**, in particular the results of the competition together with particulars of all protests lodged and Disqualifications they may have made with their recommendations to any decisions which may have to be taken for a Suspension or Exclusion.

7.2.2. Steward(s) may use any video or technological systems to assist in reaching a decision.

7.3. Clerk of the Course

7.3.1. The Clerk of the Course shall:

- a. Conduct the event in accordance with the applicable regulations, and in conjunction with the Race Director/Steward(s).
- b. Generally, keep order in cooperation with the civil authorities responsible for public safety.
- c. Ensure that all officials are at their posts.
- d. Ensure that all officials are provided with the necessary information to enable them to carry out their duties.
- e. Implement the operations with the local officials and resources, **either as the Chief official or** directed by the **Series** Race Director.
- f. Receive the reports of officials and where necessary convey to the Race Director/Steward(s).

7.3.2. The Clerk of the Course may delegate duties to one or more Deputy Clerks of the Course.

7.4. Chief Scrutineer

7.4.1. The Chief Scrutineer may be appointed by a Series, or for an Event. Only Series Scrutineers shall be responsible for the inspection of Series entries.

7.4.2. **The Chief Scrutineer shall direct the inspection of all competition vehicles. They shall** ensure the inspection of safety equipment and the inspection for eligibility of all cars prior to the first track session and at any other subsequent time.

7.4.3. **They shall** report the results of pre-race inspections, and any subsequent inspections, only to the Race Director **or Clerk of the Course**.

7.4.4. **They shall** inspect any cars damaged during track sessions **and determine if the vehicle is safe or is repaired safely**.

7.5. Chief Starter

7.5.1. The Race Director is empowered to oversee the starting of all Series races, and may designate an individual to assist the Event Starter in the proper execution of Series race starts and any restarts.

7.5.2. All competing drivers shall be under the orders of the starter from the time the cars are placed in positions on the starting grid and until the competition is completed and competing cars have left the marked racetrack.

7.6. Chief Course Marshal

7.6.1. The Chief Course Marshal:

- a. **is responsible for recruiting, training, and staffing of all marshal posts and signalling positions in use at the track.**
- b. **shall liaise directly with the Clerk of the Course regarding all marshalling matters, including ensuring all reports are provided to the Clerk.**
- c. **is responsible for briefing all marshals as to their duties, roles, and responsibilities before and during the event.**
- d. **is responsible for the safety and welfare of themselves and their fellow marshals at all times.**
- e. **shall arrange the provision of the required equipment at each post.**
- f. **signs workers logbooks and recommends promotions.**

7.7. Chief Pit Marshal

7.7.1. The Chief Pit Marshal or Chief Pit Lane Official:

- a. **is responsible for recruiting, training, and staffing of pit lane, including any specific areas such as penalty box or pit entry and exit.**

- b. *shall report to the Clerk of the Course regarding all pit lane matters including safety issues and rule infringements.*
- c. *is responsible for briefing all pit marshals as to their duties, roles, and responsibilities before and during the event.*
- d. *is responsible for the safety and welfare of themselves and their fellow pit officials.*
- e. *shall arrange the provision of the required equipment including speed measuring devices through pit lane.*
- g. *signs workers logbooks and recommends promotions.*

7.8. Chief Medical Officer

7.8.1. *The Chief Medical Officer:*

- a. *shall be a qualified Physician.*
- b. *shall be on call throughout the event.*
- c. *shall work in conjunction with the Race Director / Clerk of the Course to coordinate emergency medical response.*
- d. *is responsible for the organization and administration of medical services and equipment at an event.*
- e. *shall review the Event Emergency Plan.*
- f. *Is responsible for the recruitment of appropriately trained and qualified medical personnel.*
- g. *shall be familiar with the system to investigate deaths in the province in which the event takes place.*

7.9. Chief of Timing and Scoring

7.9.1. *The Chief of Timing and Scoring or Chief Timekeeper:*

- a. *may be appointed by a Series, or for the event.*
- b. *shall manage the timing system, processes, and records.*
- c. *shall ensure that contingencies are in place to cover potential loss of primary timing systems.*
- d. *shall prepare the grids sheets and results according to the appropriate regulations.*
- e. *shall implement the decisions of the Race Director, Steward(s) or Clerk of the Course, where these are relevant to the results.*
- f. *is responsible for recruiting, training, and staffing of other timekeepers.*

7.10. Judges of Fact

- 7.10.1. Judges of Fact may be appointed by the Race Director or the Clerk of the Course.
- 7.10.2. Starting Judges shall point out to the Race Director **or Clerk of the Course** any false starts immediately after they occur.
- 7.10.3. Finishing Judges declare the order in which cars cross the finishing line.
- 7.10.4. A protest may not be made against a decision of a Judge however a mistake by a Judge may be corrected by that Judge with the concurrence of the Steward(s).

7.11. Competition Observers

- 7.11.1. Observers may occupy posts around the racetrack assigned to them by the Race Director or the Clerk of the Course for purposes of reporting incidents which occur on the section of track being observed.

7.11.2. Flag Marshals may also be designated as observers.

8. EVENT SUPPLEMENTARY REGULATIONS

8.1. Contents of Regulations

- 8.1.1. Event organizers are responsible for drawing up and publishing Event Supplementary Regulations that need not repeat these Regulations or those of a Series being run. However, under no circumstances may they conflict with these Regulations or those of a Series.
- 8.1.2. Event Supplementary Regulations, once approved, cannot be changed prior to the start of an event unless approved by **the sanctioning body**. Changes after the start of an event can only be made with the approval of the Steward(s).
- 8.1.3. The Event Supplementary Regulations shall contain:
 - a. The name, place and dates of the proposed competition(s),
 - b. The name, address, and phone number of the promoters and/or organizers,
 - c. An announcement, accompanied by the **sanctioning body** logo; "Sanctioned by **<sanctioning body>**",
 - d. A full description of the proposed competition including length and direction of the course, and categories of cars eligible to compete,
 - e. The names of the Event Officials,
 - f. A summary of Insurance coverage,
 - g. The dates and times of the schedule of activities,
 - h. The dates of opening and closing of entries and how and where they shall be made, and the penalty for a late entry if applicable and the conditions under which entries may be refused,
 - i. The amount of the entry fee, the passes provided and the cost of additional passes to the entrants,
 - j. The times and dates fixed for personnel registration and Technical Inspection of race cars,
 - k. The location of the "Official Notice Board".

8.2. Minimum Age of Participation

- 8.2.1. Excepting ASN Canada Series registered drivers, any person not holding authorized credentials issued by the organizers, and all persons under 16 years old are not permitted to enter the pit area or any other areas which provide less protection than provided for the general public.
- 8.2.2. Working crew members - minimum 16 years of age.
- 8.2.3. Any competitor, crew or official below the age of majority in the province in which they reside must submit a completed Parental Consent Waiver.

8.3. Unauthorized Practice

During a competition, the Organizer shall not permit a Series driver or car, nor shall the driver or car participate in, the use of a marked racetrack at any time other than during the scheduled track sessions for the competition entered. The only exception shall be for specific safety reasons and only with the approval of the Race Director and Clerk of the Course.

8.4. Number of Starters

- 8.4.1. The maximum number of cars which may be on course at the same time shall be 16 per kilometre, rounded up.
- 8.4.2. This number may be adjusted for reasons of safety by ASN Canada, the Sanctioning Body, or the Series.
- 8.4.3. A racetrack is measured along the centre line of the marked track.

8.5. Competitor Information

Series Directors shall, in time for the organizer to issue entry forms, provide the Organizer with a list of entrants, drivers and cars listing the driver's full names, residences, names of primary sponsors, car types, and the racing numbers of competing vehicles.

8.6. Competitor Entry Form

Entry Forms shall contain the following:

- a. Space for the full names and addresses of the entrant, driver(s), and crew members, and the next of kin, with phone numbers, to be notified in case of emergency,

- b. Space for the signature of the entrant and driver(s),
- c. The following statement: "If an entrant, driver or crew member is under the legal age of majority, this form must be countersigned by the appropriate parent or legal guardian",
- d. Indemnity and/or declaration as prescribed in Section 8.7 and Signed by a person under the age of majority shall be countersigned by that person's parent or legal guardian whose full name and address must also be given. Space shall be provided for this purpose.

8.7. Required Indemnifications

- 8.7.1. It is a condition of any insurance policy, including the ASN Canada policy, that waivers in the form specified by ASN Canada be signed by all persons who participate in an event or who are permitted to enter areas normally closed to the public and/or paying spectators.

Only waiver forms from ASN Canada or as specified by an alternate insurer are permitted; the organizer may print their own copies of the downloaded waiver. The signed waiver forms must be kept in safe storage by the organizer for a period of not less than 2 years and shall be made available to ASN Canada on request.

- 8.7.2. Every entrant shall sign the following declaration before being permitted to take part in any competition. Such a declaration must be part of the entry form for the event:

"I have read and familiarised myself with the ASN Canada Regulations, the Series Regulations and the Event Supplementary Regulations and agree to abide by and be bound by them.

I further agree to ensure that the driver nominated by me and all crew members and guests are similarly familiarised with all Regulations and agree to abide and be bound by them."

"The entrant in signing this entry form and agreement and in consideration of the right to enter and compete in the event agrees to participate in the event and accept all risks. The entrant further agrees that the entrant, the driver and all crew members and guests shall each execute a release agreement prior to their admission to the event."

- 8.7.3. Indemnity and/or declaration as prescribed in Section 8.7 which is signed by a person under the age of majority shall be countersigned by that person's parent or legal guardian whose full name and address shall be given. Spaces shall be provided by the organizer on the entry form, or on a separate form, for this purpose.
- 8.7.4. Recognition of provincial jurisdiction. It is hereby recognized by these Regulations that the indemnities, declarations, and undertakings given in Section 8.7 may be subject to laws, statutes, and regulations of the various provinces of Canada. Organizers may therefore amend the wording but not in principle, the indemnities, declarations, and undertakings. Any such amendment of these forms must have prior approval in writing from ASN Canada.

8.8. Refusal of Entries

Organizers shall not refuse the entry of a registered Series competitor without prior agreement of the Series Director.

If an entry, or late entry, for any competition is refused subsequent to this Regulation, notification of such refusal must be sent to the Series Director and to the entrant by email, or by fax or courier letter to the address given on the entry form, as soon as possible.

Series Directors are not required to state the reason for refusal of an entry and such refusals are final and not subject to Appeal.

8.9. Falsification of Entry

An entry containing a false or incorrect statement shall be null and void and the entrant may be deemed in breach of these Regulations and the entry fee shall be forfeited.

8.10. Conditional Acceptance of an Entry

- 8.10.1. Event Supplementary Regulations may provide for conditionally accepted entries provided that the conditions are approved in advance and in writing by ASN Canada prior to notification to the entrant.

Such conditional acceptance shall be notified to the entrant at the address shown on the entry form, and the Series Director by email, courier letter, or fax, dispatched not later than the day following the closing of entries.

8.10.2. If the number of entries received exceeds the maximum number of competitors laid down by the Series or Event Supplementary Regulations, the organizer shall notify the Series Director and those to be accepted shall be selected by the Series Director.

8.11. Status of an Accepted Entry

An entry made and accepted in compliance with these Regulations and any relevant Series or Event Supplementary Regulations is a contract between a competitor and the organizers by which the competitor agrees to take part in the competition entered, unless prevented from doing so by force majeure.

8.12. Withdrawal of Entry

Except where Series Regulations provide otherwise, an entry may be withdrawn without penalty if a notice of withdrawal is received in writing by the organizer (including by email, courier letter, or fax) not less than 72 hours prior to the entry deadline date in the Event Supplementary Regulations. In such cases the organizer shall return the entire entry fee.

An entrant or driver accepted to take part in a competition and who withdraws other than in the above manner or who does not take part in the competition shall forfeit all entry fees.

8.13. Entering/Use of a Back-Up Car

8.13.1. A back-up car may be entered for a competition provided all the conditions of entering a car contained in these Regulations, the Series Regulations and the Event Supplementary Regulations are fulfilled.

8.13.2. A back-up car that was not entered before the close of entries shall be permitted late entry.

8.13.3. A driver will be allowed to practice and qualify a back-up car provided the Race Director and Timing and Scoring are notified before the back-up car is used.

8.13.4. A driver is permitted to change cars during a practice session.

8.13.5. A driver is not permitted to change cars during a qualifying session.

8.13.6. A driver having qualified more than one car shall, within 30 minutes of the close of the final qualifying session, inform the Race Director which car will be raced, and the Race Director shall cause the starting grid to be adjusted accordingly.

- a. Failure to inform the Race Director will result in the faster of the two qualifying cars being assigned a grid position. Such an assignment by the Race Director is not subject to protest or appeal.
- b. Qualifying points awarded shall be based on the qualifying position of the car selected.

8.13.7. Where a Series employs an inverted starting grid, only the fastest time achieved in qualifying by a driver, regardless of the car in which the time was achieved, will be used in determining the starting position on the inverted grid.

8.13.8. Unless stated otherwise in Series Regulations, if a car selected by a driver to race is for some reason unable to take its position on the pre-grid, the driver will be allowed to switch to a back-up car. This applies up until the time the cars leave the pre-grid area. The car will be gridded at the rear of the field.

8.13.9. A car is not permitted to be driven in a race by more than one driver, except during endurance races.

8.14. False Grid Equipment

The following equipment must be available to the False Grid officials for Series competitions:

- a. Direct voice communications with the Clerk of the Course or Race Director,
- b. A method of sounding an audible signal capable of being heard by those on the starting grid,
- c. A set of white information boards 2 ft. X 3 ft. with the following wording in large black letters:
 - "5 MINUTES"
 - "2 MINUTES"
 - "1 MINUTE"

If a True Grid is used, the same equipment should be available.

- d. One 10BC fire extinguisher.

8.15. Race Starter's Equipment

The following equipment must be available to the Chief Starter for Series competitions:

- a. Direct voice communications with the Clerk of the Course,
- b. A complete set of signaling flags according to these Regulations,
- c. A large flip-type signaling board to display race car numbers concurrently with specific flag signals,
- d. If required, a set of starting lights for standing start races installed according to these Regulations,
- e. A set of white information boards 2 ft. X 3 ft. with the following wording in large black letters:
 - "ALL"
 - "LAST LAP"
 - "LIGHTS ON"
 - "START DELAYED"

8.16. Flags and Signals

- 8.16.1. Only the flags specified in these Regulations are to be used during Series competitions. Any other flag signals, that may customarily be used locally are not to be used during Series competitions.
- 8.16.2. The Starter shall display to the race leader a "LAST LAP" board (*or other indicator documented in the Series Regulations or Event Supplemental Regulations*) indicating the driver has started the last lap and it shall be displayed to each successive car during that lap.

8.17. Timing, Scoring, Results

- 8.17.1. For all races, the timing and scoring shall not commence until the starting signal is first given by the Starter.
- 8.17.2. The Chief of Timing & Scoring shall be responsible for the accurate timing and scoring of the event and the timely publishing of such data. As a minimum they shall provide to the Steward(s) the following information:
 - The start and finish time of each Series track session.
 - The time for every car for every lap, timed to an accuracy of one thousandth of a second, during each qualifying and race session, published within 30 minutes of the end of each session.
 - A lap chart and race results for all races within 30 minutes of the end of a race.
- 8.17.3. The Chief of Timing & Scoring shall submit to the Steward(s) for approval the provisional results of a race prior to posting the results on the Official Notice Board. Results will not become official or final until approved and signed by the Steward(s).
- 8.17.4. In the event of failure of a timing mechanism, the Steward(s) shall decide the method by which cars are classified. This decision is not subject to protest or appeal.
- 8.17.5. The provisions of this Regulation in the case of oval track events may be modified by the Race Director in consultation with the Series Director.

8.18. Race Length

The scheduled race length may only be altered by the Steward(s).

8.19. Race Winner

- 8.19.1. The Starter shall show a 'Last Lap' signboard at the appropriate time.
- 8.19.2. The display of the CHECKERED flag means the race is finished.
- 8.19.3. The winner shall be the competitor that covers the scheduled distance of a race in the least time, or the greatest distance within a scheduled time for a race, and at that point receives the CHECKERED flag.
- 8.19.4. The CHECKERED flag normally shall be displayed first to the winner completing the scheduled distance or to the leader first time past the finish line after the expiry of the time of the race, and then to the other finishers as they cross the finish line. The position of the cars on the starting grid is not taken into account.
- 8.19.5. Should the leader not be running at the finish of the race, the CHECKERED flag will be displayed to the next highest running competitor.

- 8.19.6. Should the CHECKERED flag be displayed before the scheduled distance or time has been completed, the official number of laps or time shall be as at the time the CHECKERED flag is first displayed.
- 8.19.7. Should the CHECKERED flag be displayed after the scheduled distance or time has been completed, the official number of laps or time shall be the scheduled laps or time and any laps in excess shall not be counted.

8.20. Dead Heats

- 8.20.1. In the case of two or more cars crossing the finish line at the same time with no perceptible portion of one car ahead of the others, it shall be declared a dead heat and the competitors shall share equally the higher finishing position concerned.
- 8.20.2. The official finishing position of the competitors in a dead heat shall be listed as being the same in the results, and the next position shall not be awarded. The Championship points for each of the competitors involved in a dead heat shall be the average of the points involved.

8.21. Overall Race Finishers

- 8.21.1. To be classified a race finisher, a car must have completed a minimum of 50% of the total number of laps completed by the winner of the race, rounded down. Only those laps completed at the time of receiving the CHECKERED flag or the end of the race will be counted.
- 8.21.2. Finishing positions shall be determined according to the number of laps completed regardless of whether a car is running at the display of the CHECKERED flag.
- 8.21.3. Cars completing the same number of laps shall be ranked according to the time taken to complete those laps. Cars running on the track at the time the CHECKERED flag is first displayed must pass the CHECKERED flag under their own power within five minutes of the first display of the CHECKERED flag to be credited with the lap.
- 8.21.4. Cars that receive the GREEN flag (or GREEN light) starting signal during a first start of race and fail to complete the first lap of the race and any laps thereafter, shall be classified as failing to have finished the race with a designation of "DNF" in the official results.
- 8.21.5. Drivers having received a CHECKERED flag must slow down and exit the track to the pits and not pass the finish line a second time, unless directed to do so by the race officials. Unauthorized passing of the finish line will result in a minimum penalty of \$100 that is not subject to appeal.

8.22. Class Finishers (Endurance Races)

- 8.22.1. In a race with more than one class, to be classified as a race finisher and to receive championship points, competitors in each class are required to complete no less than 50% of the laps completed by the class winner.

When calculating the number of laps required to be a race finisher, the laps calculated are rounded upwards to the next whole lap.
- 8.22.2. Cars completing the same number of laps shall be ranked according to the overall time taken to complete the completed laps.
- 8.22.3. Cars running on the track at the time the CHECKERED flag is first displayed must pass the CHECKERED flag under their own power within five minutes of the first display of the CHECKERED flag to be credited with the lap.
- 8.22.4. Cars in the pits are not allowed to leave the pits after the CHECKERED flag is first displayed. Cars leaving the pits after the CHECKERED flag is first displayed are subject to exclusion from the race.

8.23. Crossing the Finish Line

- 8.23.1. A car crosses the finish line when any portion of the car first intercepts the vertical plane of the finish line.

8.24. Weighing Scales

- 8.24.1. The Organizer shall provide, on a level pad, certified scales with a certified test weight, capable of accurately weighing the heaviest expected competition vehicle, complete, and able to weigh a car at one sitting.

Such scales shall be the official event scales and the only scales that shall be used and shall be ready for use at an area set aside for Technical Inspection, at the commencement of the scheduled Technical Inspection period and shall remain available during the entire schedule of an event.

- 8.24.2. The only car weights allowed to be used for official purposes shall be those recorded by the Series Scrutineers.

8.25. Noise Level of Race Cars

- 8.25.1. Where Event Supplementary Regulations require the Organizer to limit the sound emission levels, the Organizer alone is responsible to determine the sound emissions from Series cars.
- 8.25.2. When Series Regulations require the fitting of sound limiting devices to the exhaust system of Series cars, competitors shall install and maintain the devices in place and functioning at all times during the competition.

9. CONDUCT OF RACE EVENTS

9.1. Instructions to Competitors

- 9.1.1. Instructions to the competitors may be issued by the organizers provided such instructions are first approved by the Race Director.
- 9.1.2. When the Race Director calls a mandatory driver briefing a roll call may be taken at the start of the briefing and any driver not present will be assessed a \$100 fine which is not subject to Appeal.
- A representative may be appointed to attend a driver briefing only in cases where the driver is unavailable because of competing in a different race or associated track session at the time of a mandatory driver briefing.

9.2. Qualifying for a Race

- 9.2.1. It is the car and driver combination that qualifies for a race, except in cases where more than one driver is competing in the car for an Endurance race.
- 9.2.2. A driver may not qualify a car that will be driven in a race by another driver, except in the case where the event race format specifies a requirement for a driver change.
- 9.2.3. In the case of one car and two drivers, only the nominated drivers for the car may drive the car in qualifying sessions. The official qualifying time will be the fastest time recorded by either driver.
- 9.2.4. Should the Series officials determine that a qualified car was not qualified by a nominated driver, the car will be moved to the back of the starting grid for the race.
- 9.2.5. A driver change may only take place in the official pit lane area. A violation of this rule will result in exclusion of the drivers from the session or race. Such a penalty is not subject to appeal.
- 9.2.6. A driver shall only be permitted to start a race in a properly registered Series car that has passed all technical regulations.
- 9.2.7. Ties in qualifying times between competitors shall be broken by taking the next fastest time for each competitor until the tie is broken.
- 9.2.8. Drivers who do not achieve a qualifying time may be permitted to start at the back of the starting grid only after receiving permission from the Race Director and provided the maximum number of starters is not exceeded.
- 9.2.9. A driver shall not drive another driver's car in a qualifying session or a race unless prior approval has been received from the Race Director. The penalty for violating this Regulation is exclusion of both drivers from the session. Such a penalty is not subject to appeal.

9.3. Starting Positions

- 9.3.1. Unless specified otherwise in Series Regulations, competitors shall be positioned on the starting grid in the order of their qualifying times.
- 9.3.2. Unless otherwise prescribed by the Track Permit, the pole position shall always be as follows:

- When the first turn after the start is to the right, the pole position shall be on the right
- When the first turn after the start is to the left, the pole position shall be on the left.

9.3.3. After the cars have left the False Grid for their starting positions on the True Grid, assigned starting positions must be maintained. Vacant places on the real starting grid shall remain vacant up to the display of the START flag at the start of the race, unless otherwise instructed by the Race Director.

9.3.4. Cars having departed the pre-grid to take a position on the real grid that are unable to maintain their position for any reason or are unable to respond promptly to the Starter's instructions, must abandon their starting position when so instructed.

9.3.5. Any time a driver on the real grid is unable to respond to the Starter's instructions, the driver shall stay in the car, and attempt to signal by raising both arms in the air, or in the case of a closed car by raising one arm out the driver's window, or by any other means possible.

9.4. Layout of Starting Grids

9.4.1. Rolling start grids shall be formed as follows:

- Two parallel lines,
- Two car widths separating the parallel lines,
- One car length separating the rows.

9.4.2. Standing start grids shall be formed as follows:

- Two parallel lines, staggered by row with a minimum of one car width of stagger,
- Three car widths separating the parallel lines,
- A minimum of two car lengths separating the rows.

9.5. To Be Considered a Race Starter

9.5.1. To be considered a race starter, a qualified car/driver must enter the race before the display of the CHECKERED flag. Cars that do not comply with this Regulation shall be classified as "DNS".

9.5.2. Cars are not permitted to enter the track after the CHECKERED flag is displayed. See Section 8.21.5.

9.5.3. A driver that has qualified for a starting position but does not start the scheduled race shall not receive any qualifying points.

9.6. Racing Commences at the GREEN Flag

9.6.1. A driver may only commence racing when the GREEN flag, (or GREEN light), is first shown by the Starter.

9.6.2. During rolling starts where because of the layout of the starting area all drivers may not be able to see the GREEN flag when it is first displayed, the Race Director may instruct that a GREEN flag be positioned to mirror the Starter's flag.

9.6.3. Any driver leaving the formation of the grid, and/or passing or attempting to pass before the display of the GREEN flag, or GREEN light, shall be considered to be jumping the start and shall be subject to penalty. Such penalties are not subject to appeal.

9.7. Use of a Safety Car

9.7.1. A suitable staffed Safety Car shall be provided by the organizers for all Series competitions, on stand-by and ready for dispatch at a designated location during all Series track sessions.

9.7.2. The Safety Car will be equipped with:

- a radio for two-way communication with the Clerk of the Course.
- roof-mounted flashing lights, or alternatively must display a YELLOW flag.

9.7.3. The driver of the Safety Car shall be approved by the Clerk of the Course. The passenger shall be a knowledgeable senior race official, likewise approved by the Clerk of the Course.

9.7.4. The Safety Car shall only be dispatched after declaring Full Course Yellow.

- 9.7.5. The Race Director may order the dispatch of a Safety Car if deemed necessary for safety reasons to slow down and close up the race cars.
- 9.7.6. The Safety Car, when instructed to do so, shall turn on its lights or display a YELLOW flag and shall enter the track immediately in front of the leading car. Should it fail to do so, cars following it shall be waved by the Safety Car, one at a time, until the car leading the race in first overall place is immediately behind the safety car.
- 9.7.7. The race cars behind the Safety Car must not pass the Safety Car unless indicated to do so by the official in the Safety Car.
- 9.7.8. All cars must maintain a single line behind the Safety Car.
- 9.7.9. Pit Exit will be closed when the Safety Car passes and will reopen after the last car in line behind the Safety Car passes the Pit Exit.
- 9.7.10. Prior to the restart, the Safety Car shall extinguish its lights and/or withdraw its YELLOW flag, to advise the drivers of its imminent withdrawal from the racetrack. The Safety Car shall then pull off the racetrack preceding the display of the GREEN flag **by the Starter**.
- 9.7.11. There shall be no passing until the Starter **displays** the GREEN flag. All flag stations shall drop their yellow, except in cases where a local incident requires.

9.8. Stopping/Re-starting a Race

- 9.8.1. Other than for safety reasons, the Clerk of the Course shall consult with the Race Director as to whether a race is to be stopped. The Race Director shall determine whether a race will be restarted.
- 9.8.2. The restarting of a race shall provide for the following cases:
 - CASE A:** If less than 2 laps have been completed by the lead car there shall be a new race as if the race had never started and the cars will start from their original positions on the grid.
 - CASE B:** Should a race be stopped before completion of 30% of the scheduled race length, and cannot be restarted, the race shall be deemed to be cancelled as if it had not been run. Should the race be re-scheduled at a later time or date, the cars will start from their original positions on the grid.
 - CASE C:** If more than 30% but less than 60% of the scheduled race length has been completed, the race shall not be considered complete. Should the race be restarted, either at a later time or date, it shall be restarted in single file in the order of the last completely scored lap.
 - CASE D:** If more than 60% of the scheduled race length has been completed and cannot be restarted, the race may be considered complete, and the results shall be based on the last completely scored lap. If the race can be restarted, it shall be restarted in single file in the order of the last completely scored lap.

9.9. Effect of Stopping a Race

- 9.9.1. Entry fees shall not be returned.
- 9.9.2. Series points shall be awarded on the following scale:

Laps Completed	Status	Points Award	
		Qualify	Race
0 to 2 laps	if cancelled	100%	0%
2 laps to 30%	if cancelled	100%	0%
31% to 60%	if not complete	100%	50%
61% to 100%	completed	100%	100%

- 9.9.3. Series awards other than points, if any, shall be determined by the Series Director.

9.10. Re-Scheduling of a Competition

The Series Director will attempt to re-schedule a cancelled or incomplete race. Should it not be possible to re-schedule an incomplete race it shall be considered completed and points shall be awarded as indicated in Section 9.10.

Only those cars running, or in the pits and able to run, at the time of the stoppage of the cancelled race shall be allowed to start a re-scheduled race.

A new race will not have a qualifying session and the starting grid shall be exactly that of the cancelled race.

There shall be no entry fee for the new or restarted race.

9.11. Rain Race Procedure

9.11.1. If the Race Director declares it to be a "wet race", all cars on dry tires will be allowed 10 minutes to change only to wheels upon which wet tires are already mounted.

No other work may be performed on production-based cars, however open-wheel cars may make whatever chassis adjustments, but not component replacements, that can be completed within the 10-minute period.

9.11.2. If the Race Director declares the race to be a "wet race", it is prohibited to start on dry tires.

9.11.3. When the race starts as a "wet race", any subsequent changes to other tires are at the driver's discretion.

9.11.4. If a race is started in the dry, and it starts to rain on all or part of the course prior to completion of 60 percent of the scheduled race length, the Race Director is empowered to use the procedures in Section 9.9. If a race is restarted, 15 minutes shall be allowed for changing to wheels with rain tires already mounted.

9.12. Impound Procedures

9.12.1. At the conclusion of any track session, the Race Director may select cars for inspection, and the competitors involved shall without delay take the selected cars directly to the impound area and turn them over to the Series Scrutineer.

9.12.2. At the conclusion of a race all cars are deemed to be impounded and must remain in the exact condition in which they left the racetrack until released by the Race Director or a designate.

It is incumbent on the entrant/driver to determine whether their car has been selected for inspection by reporting immediately to the impound area for inspection or release by the Chief Scrutineer or a designate.

9.12.3. Failure to present the car promptly at the impound area when requested may result in a fine and/or exclusion from the results of a qualifying session or race. Any such penalty is not subject to appeal.

9.12.4. One entrant representative must attend each car at the impound area to assist with moving the car and answer questions. Otherwise, no one is permitted to touch the car except series officials.

9.12.5. In addition to the vehicle and its components, anything mounted on or in a car may be impounded by the Race Director.

9.12.6. The entrant/driver is responsible for all costs, if any, associated with the teardown, inspection and rebuilding of any component(s) selected for eligibility verification by the Race Director.

9.12.7. A qualifying position or a race finishing position, and any Series points and other awards available to a competitor that is subjected to an eligibility verification, shall be withheld until the results of any inspection are determined.

9.12.8. The entrant/driver is responsible for assuring that the car is returned to proper operating condition after any impound or inspection by Series Scrutineers or Series technical representatives or support personnel. Protests will not be allowed in this regard.

10. ROLLING START PROCEDURES

The following is the procedure that shall be followed for all National Series races using rolling starts:

10.1.1. The cars shall be positioned on the grid in their starting position order.

10.1.2. Rolling start races shall have one pace lap, led by the Pace Car. However, should circumstances warrant, a second pace lap may be added at the discretion of the Race Director, provided all competitors are made aware of this change.

10.1.3. The Clerk of the Course shall instruct the Chief Starter or Chief Grid Marshal to display a 3-minute warning board to the field accompanied by an audible warning indicating that crew members and others must leave the grid area immediately.

- 10.1.4. At the 2-minute signal the Chief Starter or Grid Marshal shall take a position in front of the field of cars and shall give a signal to the drivers to start their engines.
- 10.1.5. Any drivers unable to respond shall so indicate immediately by raising an arm outside the confines of the bodywork.
- 10.1.6. When satisfied that all cars are ready to proceed the Chief Starter or Grid Marshal shall indicate to the Clerk of the Course that the field of cars is ready to start the pace laps.
- 10.1.7. The Clerk of the Course shall give the Pace Car the signal to proceed. The Pace Car shall not exceed 80 km/h on the pace lap.
- 10.1.8. The Pace Car shall pull off the track at the end of the first pace lap unless otherwise instructed.
- 10.1.9. The pole sitting race car will assume the role of pacing the field and will pace the field at a slow and constant speed and in accordance with instructions that may be given by the Race Director or designate.
- 10.1.10. Except for passing an obviously slowing or stopped car with a temporary or permanent problem, no passing on pace laps is permitted for any reason.
- 10.1.11. Drivers shall approach the start area in gridded formation, maintaining a car length of distance behind the car in front and a car width of distance from the car beside.
- 10.1.12. The Starter shall start the race, provided the formation of the cars is acceptable, by suddenly waving a GREEN flag continuously until all cars have passed the starting line.
- 10.1.13. Cars unable to start the pace laps in their correct grid position may start from the pit lane after cars have taken the start and all cars have passed the pit exit, and only when signalled to do so by the pit exit official.

11. STANDING STARTS USING LIGHTS

The following is the procedure that shall be followed for all National Series races using standing starts with a starting light system:

- 11.1.1. Standing start races shall have one pace lap.
- 11.1.2. On Signal from the Clerk of the Course all cars shall be moved to their assigned position on the real grid.
- 11.1.3. The Clerk of the Course shall instruct the Chief Starter to display a 2-minute warning sign accompanied by an audible warning.
- 11.1.4. At the 2-minute warning drivers shall start their engines and all crew members and others shall immediately leave the grid area.
- 11.1.5. The Clerk of the Course shall thereafter turn the control of the Start to the Starter.
- 11.1.6. The Starter having determined that all cars are able to proceed shall give the drivers a signal to depart the grid area for the pace lap. No passing is allowed on the pace lap.
- 11.1.7. The Pace Car shall normally pull off the track at the end of the first pace lap.
- 11.1.8. At the end of the pace lap the drivers will proceed cautiously to their prescribed starting position on the grid as indicated by a crew member and stop with the engine running.
- 11.1.9. The Chief Starter shall ensure that all cars are ready to start and shall turn on a RED light.
- 11.1.10. Within 4 to 7 seconds after switching on the RED light the Chief Starter will turn on the GREEN light, (simultaneously turning off the RED light), and the race will start.
- 11.1.11. Any driver unable to respond when the RED light comes on shall so indicate immediately by raising an arm outside the confines of the bodywork.
- 11.1.12. The Chief Starter may keep the RED light on and simultaneously turn on YELLOW flashing lights thereby aborting the start. In this event all drivers will shut off their engines.
- 11.1.13. The Starter shall display a "Start Delayed" sign.

- 11.1.14. When the problem has been resolved the start procedure will revert to step C) above, or as otherwise may be decided by the Race Director depending on the circumstances.
- 11.1.15. Cars unable to start the pace lap in their correct grid position may start from the pit lane after the cars have taken the start and all cars have passed the pit exit, and only when signaled to do so by the pit exit official.

12. STANDING STARTS USING FLAGS

Should a standing start race be started with flags the Starter shall use a RED flag to alert the competitors and **either a GREEN flag or the National** flag to start the race, otherwise the start system shall be the same as for a race started with lights.

13. STARTING LIGHT SYSTEMS

- 13.1.1. Where the Series promoter has designated a standing start and intends a lights system to be used for starting races, the Series promoter shall provide the following light system that must be used for the official start.
- a. The lights have the following meanings:
 - ⇒ RED: remain stationary, ready to start racing.
 - ⇒ GREEN: start racing.
 - ⇒ YELLOW flashing: remain stationary and turn off the engine (if this is switched on after the RED light, the RED light must remain switched on).
 - b. Normally the time lapse between switching on the RED light and replacing it with the GREEN will be between 4 and 7 seconds.
 - c. All lights used for signaling at the start of a race must be able to be clearly seen by all drivers seated in their cars in the normal driving position.
 - d. The RED lights must be mounted directly above the GREEN lights. The YELLOW lights may be mounted above or beside the RED/GREEN lights.
 - e. The lights must be as large as possible and practical and at least as large and intense as the permanent traffic lights used to control public roads. All the lights must be duplicated in case of bulb failure.
 - f. The switching circuit must enable any of the following conditions:
 - ⇒ All lights off,
 - ⇒ RED lights on alone,
 - ⇒ RED lights replaced by GREEN lights (one switch operation),
 - ⇒ YELLOW flashing lights on alone,
 - ⇒ RED lights and YELLOW flashing lights on together (separate switches).

14. FLAG SIGNALS

- 14.1.1. GREEN Flag
- **The GREEN flag is** used by the Starter to start track sessions and races, and by corner marshals to indicate that the track is clear.
 - **The National flag may be used to start a race instead of the GREEN flag. If the National flag is used, it must be stated in the Supplemental Regulations. All restarts shall use the GREEN flag.**
 - Some Series races may be started by using a light system.

14.1.2. YELLOW Flag

Any YELLOW flag is a signal of danger of any nature at or beyond the station displaying the flag.

Motionless: Take care, Danger beside the track, Slow down. NO PASSING FROM THE FLAG UNTIL THE NEXT FLAGGING POSITION SHOWING A GREEN FLAG.

Note: A driver may encounter several YELLOW flags before reaching the emergency area. The requirements are the SAME, SLOW DOWN, NO PASSING.

Single Waved: Great Danger next to or on the track, Slow Down significantly, Be prepared to stop. NO PASSING FROM THE YELLOW FLAG UNTIL THE NEXT FLAGGING POSITION SHOWING A GREEN FLAG.

Double Waved: Great Danger, the track may be partially or completely blocked, workers may be on the course, Slow Down significantly, Be prepared to stop or take other avoiding action. NO PASSING FROM THE YELLOW FLAGS UNTIL THE NEXT FLAGGING POSITION SHOWING A GREEN FLAG.

14.1.3. Full-Course YELLOW

A full yellow condition is required whenever it becomes necessary to dispatch an ambulance or other service vehicle onto the racing surface. During a full-course yellow, the Starter will display two (2) yellow flags. Double steady yellow flags will be displayed at all flag stations around the circuit to indicate a full-course yellow condition.

During a full-course yellow, a Safety Car may be directed onto the circuit. The purpose of this vehicle is to pace and direct the field of race cars until such time as the racetrack has been determined fit to resume competition. Refer also to Section 9.8 regarding the use of a Safety Car.

14.1.4. RED Flag at Start/Finish and at all Posts

Should a decision be made to stop any track session, including a race, because of an accident or an incident, a RED flag will be waved at the Start/Finish line and simultaneously each corner post will wave a RED flag.

It is the responsibility of all drivers to stop racing immediately, slow down, exercise extreme caution, be prepared to stop, and proceed to pit lane, or as otherwise directed by an official.

Cars entering the pits must stay in single file in the pit lane away from the working area. If during a qualifying or race session, no work or service shall be performed on any cars until after the track has been re-opened, except under the direction of the Race Director.

14.1.5. BLACK Flag with "ALL" Displayed by the Starter

Informs the drivers that a track session has been halted because of a reason other than accident or incident. Drivers shall stop competing, no passing, reduce speed, and proceed to their pits.

Cars entering the pits must remain in single file and stop in the pit lane away from the working area. If during a qualifying or race session, no work or service shall be performed on any cars until after the track has been re-opened, except under the direction of the Race Director.

14.1.6. BLUE Flag

Motionless: A faster car is closing and is about to overtake you. Watch your mirrors.

Waved: A faster competitor is trying to overtake you. When shown, the driver receiving the Blue Flag must allow the following car to safely pass at the earliest opportunity.

14.1.7. YELLOW Flag with RED STRIPES

Advise drivers to take care. Used to indicate a slippery surface such as the presence of oil, water and/or debris on the surface.

14.1.8. WHITE Flag

Informs driver that a vehicle which is traveling at a much slower speed than the competing cars is on the track. The slow-moving vehicle might be an ambulance, service vehicle or a slow-moving race car.

14.1.9. DIAGONAL BLACK and WHITE Flag, with CAR NUMBER Displayed

Warns the driver of unsportsmanlike or unsafe conduct and that a penalty may be pending. Flag is only used once. It is displayed only by the Starter.

14.1.10. BLACK Flag, with CAR NUMBER Displayed

Informs the driver to complete the current lap and stop for consultation at their pit, or at a location designated by the Race Director. It is displayed by the Starter and may be displayed at a second location if described in the Supplementary Regulations.

Failure to comply within four laps may result in disqualification.

14.1.11. BLACK Flag with an ORANGE DISK, WITH CAR NUMBER DISPLAYED

Informs the driver of a mechanical problem likely to cause danger and to reduce speed and stop at the pits. Also known as a mechanical black flag. It is displayed by the Starter and may be displayed at a second location if described in the Supplementary Regulations.

Failure to comply may result in a Black Flag or further penalties.

14.1.12. CHECKERED Flag

A BLACK and WHITE CHECKERED flag. Racing must stop and all drivers must slow down, complete one more lap and return to their pits or other designated area.

15. COMPETITOR CONDUCT ON THE RACETRACK

15.1. General

- 15.1.1. Engines must be started by means of an on-board starter using an on-board power supply, with or without a supplementary power supply.
- 15.1.2. It is not permitted to drive a race car, at any time, in the opposite direction of race traffic without the permission of the Clerk of the Course. Infractions of the Regulation may result in immediate exclusion.
- 15.1.3. If a driver is forced to stop on the track it is the driver's duty to place the car as far as possible off the travelled portion of the track to cause the least obstruction to other competitors, and preferably on the side of the track least used by race traffic.
- 15.1.4. The driver of a stalled car should raise one or both arms to indicate that the car will not move until the track is clear.
- 15.1.5. Cars shall not be moved under power of the on-board starting device while on the racetrack to maintain or improve a race position. Using the on-board starter to move a car to a safe location is permitted.

15.2. Conduct During Race Starts

- 15.2.1. Entrants, drivers, or crew members, who demonstrate a lack of compliance with race starting procedures are subject to penalty.
- 15.2.2. A false start shall be deemed to occur when a driver at any time under Starter's orders, unless instructed by an official, moves from the prescribed position, forward, backwards, or sideways in relation to the field before the display of the GREEN flag, or GREEN light, indicating the start of a race.
- 15.2.3. The following violations are subject to either a stop-and-go penalty after the start or restart of a race, or a 1 lap penalty at the end of the race:
 - a. Making or attempting to make a false start.
 - b. Passing a Pace/Safety Car without being instructed to do so by the safety car official.
- 15.2.4. Penalties applied under this Regulation are not subject to appeal.

15.3. Push-Starting a Car

- 15.3.1. During any on-track session, cars in the pits are not allowed to be push-started. The on-board starter, and auxiliary starter if permitted by Series Regulations, must be used.
- 15.3.2. Push-starts are allowed only during pre-grid and true grid activities.
- 15.3.3. Push-starts on the racetrack are not permitted.

15.4. Conduct on the Racetrack

- 15.4.1. Only the marked racetrack surface and any curbing may be used by drivers during any track session.
- 15.4.2. Drivers shall always drive in a manner compatible with general safety respecting the right of competitors to space marked on the racetrack.
- 15.4.3. It is the responsibility of all drivers to avoid physical contact between cars on the racetrack.
- 15.4.4. Drivers shall follow the marked track during a competition and shall not gain an advantage from an off-course excursion.

- 15.4.5. Any driver who has left the marked track with all four wheels must regain control of the car, stop if necessary, and, without driving against the direction of the racetrack, rejoin the track at the nearest point to that where the exit occurred, compatible with safety, and obey the directions of the track marshals in the area.
- 15.4.6. A driver who goes off the marked track, in the presence of track marshals or not, and attempts to return to the track and in doing so causes a disadvantage to another competitor is subject to penalty.
- 15.4.7. The repetition of serious mistakes or the appearance of a lack of control over the car (i.e., leaving the marked track) may entail exclusion or other penalty of the driver involved.
- 15.4.8. The Race Director may, during any on-track session, order any car removed from the racetrack which, in their opinion constitutes a hazard to other competitors because of insufficient speed, fluid spilling, or any other reason. Such action is not subject to appeal.
- 15.4.9. All major body components shall remain in the normal position throughout the competition. Loss of bodywork may result in a car being shown a mechanical BLACK flag on instruction from the Race Director.
- 15.4.10. Before entering the pits from the track, the driver should signal by raising an arm.
- 15.4.11. A driver may not improve a race position by entering or traversing through the pits, regardless of whether a stop is made.
- 15.4.12. Except in cases of force majeure, drivers exiting pits and drivers on track shall ensure that none of their tires touch the blend line. Penalties applied for violation of this Regulation are not appealable.

15.5. Passing on the Racetrack

- 15.5.1. It is the responsibility of both the overtaking Driver and the Driver being overtaken to assure safe overtaking. Where two cars are reasonably alongside each other, each must permit the other 'racing room'. Overtaking may be either right or left depending on prevailing conditions.
- 15.5.2. For the conduct of all sessions, the racing surface shall be defined as the marked paved track and its curbing only. Pit Lanes, their entries and exits, runoffs are not part of the racing surface. A Driver may not improve his position or gain an advantage by leaving the racing surface.
- 15.5.3. All Drivers have a right to 'racing room' on the racing surface which is defined as having sufficient space to allow a Driver to maintain control of his vehicle in close quarters under racing conditions.
- 15.5.4. Failure to follow the prescribed racing surface may result in penalties. During Practice and Qualifying, a time may not be given for any lap where a Driver 'shortcut' the course. During a Race, any advantage in time/position gained as a result of a 'shortcut' of the course may result in a 'Drive Through' or other penalty as determined by the Race Director or Steward(s).
- 15.5.5. Blocking is defined as being "Movement In Reaction" and also includes taking an unusual or abnormal line to inhibit or prevent passing.

16. RULES OF THE PITS

16.1. General

- 16.1.1. At the start of any race, the pit lane must be absolutely clear.
- 16.1.2. All crew members working in the pit area must be clean and fully clothed during any track session. Shirts, long pants, and closed-toe footwear are mandatory.
- 16.1.3. Crew members shall not sit on the pit wall during any track session.
- 16.1.4. A maximum of 2 people per car shall be permitted access to a designated location for the purpose of signaling during any track session. Signalers may not be at the signaling area until after the start of the race.
- 16.1.5. Before entering the pits from the racetrack, a driver should signal by raising an arm clear of the car's body work.
- 16.1.6. Should a pit-bound driver overshoot the car's pit location, the car must stop and be pushed back to their pit by hand or else continue for another lap.

- 16.1.7. No car shall be driven backwards under its own power in a pit lane at any time, for any reason.
- 16.1.8. No car may be pushed back to its pit under conditions that would constitute a hazard.
- 16.1.9. Cars shall enter and exit the racetrack only from the pit area. Disabled cars shall be removed to the paddock during any track session, if possible.
- 16.1.10. During a qualifying or race session, if a car is to be taken from the pits to the paddock and return to the session the following must occur:
 - a. Permission must be received from the Race Director prior to the car leaving the pit area.
 - b. The penalty for leaving Pit Lane without permission during a Qualifying Session is the loss of session times. If it occurs during a race, the penalty will be Exclusion from the results.
 - c. An Observer designated by the Race Director will typically accompany the car and confirm to the Race Director that only the authorized work was performed.
 - d. Failure to comply may render the car ineligible to return to the session with possible additional penalties.
- 16.1.11. Smoking or vaping is not permitted at any time in the pits.

16.2. Pit Lane Speed Limit

- 16.2.1. The pit lane speed limit is 60 km/h, unless otherwise specified in the Series Regulations or Event Supplementary Regulations.
- 16.2.2. A penalty regarding a pit lane speed violation is not subject to Protest or Appeal.

16.3. Pit Stops

- 16.3.1. When a car stops at its pit at any time during qualifying or race sessions when work or service on the car is permitted:
 - a. No more than 5 people, including the driver, even if the driver remains in the car, shall touch the car, or in any other way whatsoever provide assistance.
 - b. Any team member in the working pit is deemed to be working on the car except the person in charge of the fire extinguisher provided such person does not touch the car.
 - c. In the case of a driver change, such as during endurance events, a driver being replaced may assist the replacing driver to prepare for driving but may not work on the car in any other way. Should a driver participate in the servicing of the car in any way, the rule of 5 people applies.
 - d. Identifiable Series-appointed service company personnel examining a car's components or equipment are not counted.
- 16.3.2. An on-board air jacking system or a manually operated external jack may be used to lift the vehicle. When using an external jack, only one jack per vehicle can be used during a pit stop.
- 16.3.3. The addition of any fluids to a car during a race is prohibited, except during endurance races.
- 16.3.4. It is the responsibility of the crew to notify the pit marshals immediately of any liquid spills and to assist in their clean-up.
- 16.3.5. No work shall be performed under a car unless jacking stands are in position.

16.4. No Refuelling in Pit Lane

Excepting endurance races, refuelling in the pit lane is prohibited during any track session unless authorized by the Race Director.

16.5. Generators in the Pits

All electrical generators and air compressors must be equipped with spark arrestors. They cannot be placed in the working pit lane. They must be located as far away from fuel containers as possible.

16.6. Other Devices in the Pits

- 16.6.1. Compressed gas cylinders must have a protective structure around their gauges and valves when in the working pit area.

16.6.2. No tools which may by their use readily cause flame, sparks or a high temperature are permitted in the pit area.

16.7. Exiting the Pits

16.7.1. Drivers entering the racetrack from the pit lane shall first receive permission to do so from the pit exit official (or obey the pit exit lights if used) and be prepared to slow significantly or stop if requested.

16.7.2. Notwithstanding having received permission to enter the track from the pits, drivers shall not cross the blend line while exiting the pit lane. Drivers on the race line shall also not cross the blend line. See Section 15.4.12.

17. REFUELLING (ENDURANCE RACES)

17.1. General

17.1.1. Refuelling and the addition of lubricants is only permitted during practice and the race, not during qualifying.

17.1.2. During refuelling, cars must have at least two wheels on the ground.

17.1.3. During refuelling, no person(s) shall be under the car.

17.2. Refuelling Personnel

The person operating the fuel nozzle must wear a one or two-piece suit, socks, hood and gloves and shoes made of approved fire-retardant material, plus a full-face helmet and face shield.

Another crew member must operate the deadman valve at the overhead tank. (See Section 24). This person must be attired in safety gear the same as the person handling the fuel nozzle.

A fire safety person with a minimum 10BC fire extinguisher must monitor the refuelling operation at the car.

A broom, shovel, and container holding sufficient absorbent material shall be available to remove fuel and fluid spills during any pit stop.

The contaminated absorbent material shall be collected by the refuelling personnel and disposed of in a metal container with a lid.

REPEATED FUEL SPILLS, OR ANY FUEL SPILL DEEMED EXCESSIVE WILL BE SUBJECT TO A PENALTY.

18. PADDOCK SAFETY

18.1.1. No vehicle is permitted on the marked racetrack at any time during an event without permission from the Clerk of the Course.

18.1.2. Team vehicles of any kind are to be driven in a safe manner when at the race facility and no vehicle shall be driven faster than 15 km/h in the paddock.

18.1.3. No person shall ride in or on a car or other vehicle in an unsafe manner.

18.1.4. When a car is being refuelled, or a device is being used that could precipitate a fire, such as a welding system, a crew member shall stand-by with a minimum of a 10BC fire extinguisher.

18.1.5. Any fuel transfer including refuelling must not be performed under an awning or where fumes could accumulate.

18.1.6. Animals of any kind are not permitted in the pit or on the marked racetrack. Animals in the paddock must be restrained.

18.1.7. The Regulations in this section, and any penalties applied, are not subject to Protest or Appeal.

19. OVAL TRACK RACES

19.1.1. The organizer of an oval track race shall comply with these Regulations excepting that the procedures for the control of on-track sessions may be varied to suit the differing requirements of an oval event.

- 19.1.2. The organizer of an oval track race shall include detailed operating procedures for flag signals, practice procedures, qualifying procedures and race starting and re-starting procedures in the proposed Event Supplementary Regulations at the time of application to ASN Canada for an organizing permit.
- 19.1.3. Entrants and drivers shall abide by oval track Event Supplementary Regulations.
- 19.1.4. Series Regulations car specifications shall be maintained at oval track events.
- 19.1.5. Driver on-track conduct principles contained within these Regulations shall be maintained.
- 19.1.6. Protests or appeals during or after oval track competitions will not be allowed based on misunderstanding by competitors of the difference between oval racing Regulations and road racing Regulations, including the difference in meaning between oval racing flag signals and road racing flag signals.

20. RACE CARS GENERAL

20.1. General Safety Matters

- 20.1.1. Unless otherwise stated in these Regulations, or in those of a Series, all cars shall comply with these ASN Canada Regulations regarding car safety equipment.
- 20.1.2. Cars shall, as a minimum, be equipped with roll-over protection meeting ASN Regulations and standards and as may be further specified in Series Regulations or as accepted homologations.
- 20.1.3. In case of production-based ('showroom') Series cars, the roll cage must be bolted (not welded) into the car. The roll cage mounting plates, and any metal spacer plates, must be in direct contact with the metal floor of the car and not be bolted through the floor carpet or carpet underpad. Padding of the roll bar around the driver is mandatory. (See Section 28).
- 20.1.4. All other Series cars must have a roll cage welded to the structure of the car, or as-per the manufacturers Homologation Documentation.
- 20.1.5. The Chief Scrutineer has the final decision if a roll cage installation is acceptable. This decision is not subject to appeal.
- 20.1.6. Series Regulations may require the fitting of specified fire extinguisher systems. In such cases the systems specified must be maintained in an operable condition during all on-track sessions
- 20.1.7. Passing the annual or event inspection is not a guarantee of vehicle safety. It is the responsibility of Entrants to follow the manufacturer's recommendation for all safety equipment.

20.2. Technical and Safety Inspection

- 20.2.1. The responsibility to ensure that the car and driver's equipment complies with all Regulations and is safe, rests solely with the entrant and driver. The very act of presenting a car for any Technical Inspection is deemed to be recognition of this Regulation.
- 20.2.2. Any inspection of a car is not a guarantee of the safety of the car.
- 20.2.3. All cars in all Series shall be inspected and an entry made in the vehicle technical paperwork before the car enters the track for the first practice session of every event. A sticker shall be issued to each car passing through Technical Inspection and must be placed on the upper right-hand corner of the windshield or as requested by the scrutineer on closed-wheel cars, and on the right-front upper suspension arm of open-wheel cars.
- 20.2.4. Cars may be re-inspected at any time at the discretion of the Race Director, Steward(s), or **Chief** Scrutineer.
- 20.2.5. Decisions of the Chief Scrutineer regarding safety matters are final and not subject to appeal.

20.3. Decals and Advertising

- 20.3.1. ASN decals must be placed on all Series cars, one on each side and one on the front, placed on the body above a line passing through the centre of the wheels and be readily visible.
- 20.3.2. Decals and emblems of conflicting Series and events must be removed.

- 20.3.3. The driver's name in clearly legible block letters at least 2-inches high and in a significantly contrasting colour, must appear on each side of the car. On production-based cars, the location shall be on the roof above the driver's window, or as otherwise specified in the Series Regulations.
- 20.3.4. Advertising and symbols displayed on a car must be in good taste and not interfere with racing numbers or other required markings.

20.4. Appearance of Cars

- 20.4.1. The body condition, paintwork, and signage (decals) of a car shall always remain intact. Cars will not be permitted to compete in a competition with damage from a previous competition that has not been repaired in a workmanlike manner.
- 20.4.2. Reasonable efforts must be made to restore the appearance of a car damaged during an event prior to the start of a race.
- 20.4.3. A car that is visually unacceptable, in the opinion of the Race Director in consultation with the Series Director, will not be permitted to start a race. This decision is not subject to appeal.
- 20.4.4. A claim for return of entry fees resulting from the Race Director's decision is not allowed.

20.5. Racing Numbers

- 20.5.1. Racing numbers shall be applied only as follows, or as per the Series Regulations:
- The numbers must be at least 10-inches high on production-based cars, and 8-inches high on open-wheel cars. The minimum width of stroke of all numbers is 2-inches.
 - The numbers must be in a solid colour, on a solid background of a significantly contrasting colour. Black on white is preferred and recommended.
 - One number must be on the front hood of production-based cars and on the nose of open-wheeled cars.
 - One number must be on each side of the car positioned on the body above an imaginary line running through the centre line of the wheels. Open wheel cars may vary this location.
 - On production-based cars, a racing number, one-half the size of the normal number, must be placed on the rear of the car on a vertical surface and must be CLEARLY VISIBLE AND LEGIBLE.
- 20.5.2. Metallic or other highly reflective numbers are not permitted.
- 20.5.3. Cars not meeting the specifications of this Regulation, in the opinion of the Race Director, during any scheduled track session will be BLACK-FLAGGED and not allowed to re-enter the track until the numbers are in compliance.

20.6. Race Car Technical Documentation

- 20.6.1. Every vehicle entered in a series must have technical paperwork consisting of identifying information about the chassis and engine, date of last inspection, records of damage and repairs, or any other information relevant to the Series and Chief Scrutineer. This may be in the form of an issued logbook, a Technical Passport, Homologation Documentation, or any other form defined by the Series. This may also be in electronic form.
- 20.6.2. A Vehicle Logbook may be issued by the Chief Scrutineer who must complete the required car information in the front of the Logbook. Only one Logbook shall be issued for each car (other than by way of extension or replacement). Possession of two logbooks for one car at one time shall be deemed a breach of these Regulations.
- 20.6.3. The vehicle technical paperwork must be presented by all competitors at all ASN Canada competitions. Failure to present at the time of Technical Inspection will result in a \$250 penalty which is not subject to Protest or Appeal.
- 20.6.4. Entrants/drivers who do not have their technical paperwork available shall not delay the inspection of cars that do and shall arrange with the Chief Scrutineer an appropriate time for inspection of their car prior to being accepted for competition.
- 20.6.5. During Technical Inspection, deviations from technical Regulations, for which a waiver is granted under Section 23.1.2) by the Race Director, shall be noted in the vehicle technical paperwork. The terms of such waivers must be noted in the vehicle technical paperwork and must be complied with by the competitor.

- 20.6.6. If a car is damaged during an event, ***the scrutineers shall be notified by Race Control. The vehicle shall then be inspected by a scrutineer and*** the details shall be noted ***by the scrutineer*** in the vehicle paperwork. ***It should be noted if the vehicle requires re-inspection before competing again.***
- 20.6.7. Logbooks from an ACCUS-affiliated series will be accepted where applicable.

20.7. Measurement of Cars/Components

- 20.7.1. When a car, or components thereof, is subjected to an eligibility inspection, all values; shapes, dimensions, materials, weights, electrical values, torque values, etc., shall be measured "as-is".
- 20.7.2. In the case of Series production-based cars the values referred to in Section 20.7.1) shall be compared to these Regulations, the Series Regulations and any technical manuals published by the car's manufacturer.
- 20.7.3. There shall be no tolerance of the values measured other than as may be specified in these Regulations and Series Regulations, or by nature of the tolerance of the measuring equipment. The vehicle manufacturer's official manuals or homologation documents, and supplements or amendments thereto shall be referenced for tolerances.
- 20.7.4. When repairs to a car's components are permitted by the Series Regulations, only the least wear limit, where the manufacturer's official manuals, supplements and amendments thereto specify a range of wear limits, are permitted.

20.8. Race Car Weights

- 20.8.1. A car must weigh no less than the minimum weight set forth in the Series Regulations at all times during an event and must be in conformity with these Regulations and Series Regulations and be equipped with all required car safety equipment at the time of any official weighing.
- 20.8.2. Unless specified otherwise by the Series Regulations, only the overall weight, as determined by the Series Regulations, shall be referenced.

20.9. Engine Fuel to be Used

- 20.9.1. Unless otherwise specified in Series Regulations:
- a. Engine fuel means premium unleaded hydrocarbon type gasoline that is typical of most premium unleaded gasoline.
 - b. Series cars shall only be fuelled with gasoline normally available from Canadian commercial roadside gasoline outlets.
- 20.9.2. Unless specified otherwise in Series Regulations, the addition of substances of any kind whatsoever to the fuel described in this Regulation, either directly to the fuel or by any other means, is not permitted.
- 20.9.3. Fuel samples may be taken by the Scrutineers at any time and laboratory analysis may be performed. The findings of any analysis performed are final and not subject to protest, and any penalties arising from such analysis are not subject to appeal.

20.10. Race Tires

- 20.10.1. Series Regulations may specify particular tires for use by competitors during competitions and in such cases these are the only tires permitted.
- 20.10.2. Modification of any kind to a Series specified tire by competitors is prohibited unless permitted by Series Regulations.

21. IN-CAR CAMERAS/RADIOS

- 21.1.1. In-car camera or video recording equipment is permitted provided the installation is approved by the Chief Scrutineer and subject to the provision that any video recording made during a track session may be impounded by the Race Director.
- 21.1.2. Excepting the receiving of standard broadcast radio signals, it is prohibited that telemetric signals be transmitted from or received by any car during any official on-track session unless prior express written consent is received from the Race Director in consultation with the Series Director. Series Regulations may permit two-way voice-only radio communications.

- 21.1.3. Two-way voice communication is permitted between the driver and crew, when allowed by the Series Regulations. For further clarity, in-car voice communications between drivers are not permitted.
- 21.1.4. Any radio communications used must not interfere with race control or any other racetrack emergency network. A team representative must inform the Race Director of the team's radio frequency.

22. SEALED COMPONENTS

- 22.1.1. Series cars that are required to have components sealed, by wire, paint or any other means specified in the Series Regulations, shall always have such seals in place and undisturbed.
- 22.1.2. It is the competitor's responsibility to assure the presence and integrity of any seals.
- 22.1.3. Seals found to be missing, broken, altered, or showing evidence of tampering, by the Scrutineers in any technical inspection after a qualifying session or a race may result in a car being assessed a fine and/or declared ineligible and may result in exclusion from the session or race.
- 22.1.4. When a sealed component requires repair or replacement, it is the competitor's responsibility to arrange with the Chief Scrutineer the appropriate inspections when the work is in progress and when a seal is being replaced.
- 22.1.5. Penalties under this Regulation are not subject to appeal.

23. PRODUCTION-BASED or HOMOLOGATED SERIES CARS

23.1. General

IF THE REGULATIONS DO NOT STATE THAT YOU CAN DO IT, YOU CANNOT

- 23.1.1. Only the Race Director, in consultation with the Chief Scrutineer, may authorize replacement, adjustment, or modification to a vehicle that is not covered by the Series Regulations and Bulletins. The authorized change may be for technical or safety reasons.
- 23.1.2. Under unusual circumstances it may be reasonable to permit a competitor to vary from a specification otherwise not permitted by these or Series Regulations, such as in the case of a repair of a chassis after an accident, and only if such permitted variance clearly will be of no consequence to the safety or performance of a car.

Request for permission for such variance must be submitted to the Race Director in writing. The permission may be granted by the Race Director, in consultation with the Chief Scrutineer and a technical representative of the manufacturer of the car. Any such authorized variances may be temporary or permanent and must be entered in the Vehicle Technical Documentation.

Competitors who allow or take it upon themselves to make such variances to Series cars, without first receiving written permission, may not pass inspection, and may be excluded from a competition.

- 23.1.3. The onus is always on the competitor to ensure the eligibility of a Series Car.
- 23.1.4. The intent of production-based or homologated racing is to maintain the original specifications of a car and to allow only modifications provided for in these and Series Regulations.

Production-based cars shall remain as originally manufactured, and homologated cars shall remain as originally homologated, and unless these Regulations or Series Regulations state that modifications must be made, or specific variations to the manufacturer's specifications are permitted, no additional modifications or variations are permitted.

This is the basis of the on-going eligibility of a car.

- 23.1.5. In determining questions of eligibility of a car or of the condition, presence, or absence of a component of a car, ASN Canada officials shall be guided by the principle of... "IF THE REGULATIONS DO NOT STATE THAT YOU CAN DO IT, YOU CANNOT".

On the other hand, a protest against a car, that is for example based on the absence of a tire valve cap, or the absence of a cigar lighter, will be deemed vexatious.

23.2. Required Modifications

- 23.2.1. All cars must be fitted with roll cages complying with Section 28 of these Regulations.
- 23.2.2. All closed (sedan-type) cars must be fitted with a window net on the driver's door, except in cases where a series-approved driver's door window is securely affixed. This net must be securely mounted to the roll cage and/or main structure of the vehicle, and NOT to the door. Should the car retain the original or OEM driver door window, it must be in the down position and the use of a window net is mandatory.
- 23.2.3. An approved rain light must be installed, and the driver must be able to activate while sitting normally in their race seat. It is recommended to use an FIA-approved rain light.
- 23.2.4. A master electrical switch, operatable from both the driver and from someone outside the car, must be installed. The switch must disable all vehicle electrical system, except for the fire extinguisher system. It must be installed on the positive side of the electrical system, not the ground. The terminals of the switch must be insulated. The switch must be identifiable with the official international marking. The off position must be clearly indicated.
- 23.2.5. Tow hooks or tow straps are required at each end of all cars. They must be capable of pulling the maximum weight of the car without failure. They must be obvious, or their location identified with the official international marking.

23.3. Allowable Modifications

- 23.3.1. The addition, but not the replacement, of gauges for the measurement of temperature of engine coolant and oil, and electrical voltage or amperage gauges, is authorized providing the manufacturer's dashboard remains standard.
- 23.3.2. Wheel alignment adjustments must not exceed the limits of adjustment as specified in the manufacturer's manual or homologation papers for the car unless specified otherwise in the Series Regulations.
- 23.3.3. The interior rear-view mirror may be replaced by another of a different type and/or dimensions provided such replacement does not constitute a safety hazard in the opinion of the Chief Scrutineer.
- 23.3.4. Where changes are required to enable drivers with physical disabilities to compete, those changes must be approved by the Chief Scrutineer and must not compromise the safety of the vehicle.

23.4. Restrictions

- 23.4.1. There shall be no additional instrumentation of any kind fitted to Series cars during a competition unless specifically authorized by the Series Regulations.
- 23.4.2. Ballasting of cars by any means is not permitted, except where allowed in the Series Regulations.
- 23.4.3. The rear brake lights must be operational at all times and controlled only by application of the service brake pedal or approved steering-wheel brake system by the driver. The centre brake light must not be covered or obscured in any way. The rear brake lights may be covered by tape or decals to a MAXIMUM of 50% of the total brake lens area.

23.5. Series Cars on Public Roads

It is always the competitor's responsibility to assure that Series cars, when driven on public roads, comply with the laws of the land.

24. ENDURANCE RACING REFUELLING EQUIPMENT

- 24.1.1. The use of dump cans to refuel cars is permitted, providing it uses a dry break system.
- 24.1.2. An approved jerry can for refuelling is permitted with the OEM fuel filler neck.
- 24.1.3. An overhead rig is permitted. If an overhead rig is used, it must only operate by gravity feed.
- 24.1.4. No cooling or pressurising of refuelling systems is permitted.
- 24.1.5. The refuelling rig must:
 - a. Be of the stationary overhead type (no wheels or casters),
 - b. Have a maximum overhead height of six feet seven inches (6'7"),
 - c. Have a maximum capacity of 48 imperial gallons.

- 24.1.6. The refuelling rig stand must be constructed of suitably strong materials and must have a neat and clean appearance. The stand must have wide footings to prevent tipping over.
- 24.1.7. The fuel container may be:
- Fabricated from steel or aluminum.
 - May be a 45 imperial gallon steel drum.
 - May be of the bag or bladder type.
- 24.1.8. Containers, unless of the bag type, must be vented to the atmosphere.
- 24.1.9. Placing weighted objects on top of elevated fuel bladders is prohibited.
- 24.1.10. Refuelling rigs must be grounded by a sturdy metal cable or wire to a three-foot metal stake driven into the ground or facility-provided grounding wire.
- 24.1.11. Electric lights or electrical devices of any kind may not be attached to any portion of the fuel rig.
- 24.1.12. All fuel must:
- Pass from the overhead container directly through a manually operated valve, deadman type shut-off valve (spring-loaded to the OFF position) located on the fuel container.
 - Then pass from the deadman valve to a single one-inch inside diameter, rubberized gasoline-compatible fourteen-foot maximum length refuelling hose.
 - Then pass through a manually operated standard Underwriter Laboratories (UL) 842 approved, unleaded gasoline filler nozzle with all locks and latches removed. The inside diameter of the refuelling nozzle tube must not exceed 0.75 inches.
 - Conical nozzles, centering devices and the like are prohibited.
- 24.1.13. Any quick-disconnect fittings used in the system must have their latches positively fixed to prevent separation of the system.
- 24.1.14. No modifications are allowed to the filler neck on the race car.
- 24.1.15. The complete refuelling rig (including legs, fuel container, extensions and deadman valve) must be set back a minimum of 24 inches from the back side of the working lane pit dividing guard rail or wall.
- The only components of the refuelling system that may penetrate the vertical plane 24 inches behind the pit wall are the one-inch refuelling hose and the fuel filler nozzle.
- 24.1.16. The overhead fuel container can only be filled by means of a manually operated transfer pump or a UL-Approved explosion proof electric pump with explosion proof connections to the electrical source. Fuel shall not be pumped or otherwise transferred into the overhead rig while a car is being refuelled.
- 24.1.17. Other special refuelling conditions may be applied at each event as may be necessary or required for safety reasons.

25. FIRE EXTINGUISHERS

25.1. Extinguisher Systems

A fire extinguisher/extinguishing system must be carried on all vehicles, the minimum rating being 1.5 kg or 3.3 lbs. It should contain either BCF or BTM extinguishant and be operable by the driver while normally seated either by contact or mechanically assisted or electrically assisted triggering system; such electrical activation must be via a system independent of the vehicle electrical system, such as a self-contained 9V battery. Hand operated extinguishers must not be carried loose.

Fire Extinguisher Capacities

- 1.5 kg capacity for discharge into both cockpit and engine compartment.
- 2.5 kg capacity for discharge into both cockpit and engine compartment. Plumbed-in system.
- 5 kg capacity for discharge into both cockpit and engine compartment. Plumbed-in system.
- 5 kg and 2.5 kg capacities for discharge into engine and cockpit compartments respectively.

The 5 kg unit to be plumbed-in for the engine compartment and the 2.5 kg unit (not plumbed-in) to be at the disposal of the driver.

The 5 kg unit should have two points of triggering, one for the driver and one outside the car, clearly marked.

The triggering point from the exterior must be positioned close to the circuit breaker (or combined with it) and must be marked by the letter "E" inside a white circle of at least 10 cm. diameter with a red edge.

When installing units, the direction of the nozzles should be carefully considered. Engine induction, exhaust, ignition, and fuel pumps are the most likely areas for fire to occur.

The units should function in any position, even if inverted.

25.2. General

It is recommended that all fire extinguisher systems, both plumbed-in and hand-held, be securely mounted within the main structure of the vehicle.

It is prohibited to mount extinguisher bottles of over 2.5 kg outside the main structure of the vehicle.

NOTE: The capacities quoted are minimums and can be exceeded.

NOTE: It is the responsibility of the competitor to assure the integrity and operating ability of an installed extinguisher.

All extinguishers must carry a certification sticker. Should a certification sticker not indicate the next service date, it is assumed to be 2 years after the last service date. All extinguishers must be within their validity period, based on the certification.

25.3. Hand-Held Extinguishers

Extinguishers should be retained in positive quick-release brackets, secured to the vehicle by a minimum of two 6mm bolts.

An extinguisher need not be able to be removed by the driver while competing but must be able to be removed with a minimum of effort and without the use of tools.

Extinguishers with pressure gauges are recommended.

The tare weight of the extinguisher must be clearly marked on the cylinder.

25.4. Plumbed-In Extinguishers

25.4.1. All bottles should discharge simultaneously and must be operable in any position in the vehicle.

25.4.2. It is recommended that extinguisher bottles be installed in the longitudinal direction of the vehicle.

25.5. Method of Operation

25.5.1. The preferred method of operation is electrical, and an installed system should have its own source of energy for triggering and actuation, ideally with provision for testing the integrity of the triggering and actuation circuit.

25.5.2. Mechanically operated systems, if used, should be fitted with "Total Discharge" valves that continue to discharge even if the actuation mechanism should fail after triggering.

25.5.3. Hand-held extinguishers which have been adapted by the addition of pull-cables are not acceptable.

25.6. Weight Checking

25.6.1. Extinguisher systems should be capable of being dismantled for the purpose of checking the weight, checking the integrity of the cylinder, and to allow the triggering and actuation system to be serviced without discharging the contents of the extinguisher.

25.6.2. The tare weight of the extinguisher must be clearly marked on the cylinder(s).

25.7. Installation

25.7.1. Particular attention should be paid to the installation and maintenance of any system, especially if it is mechanically operated. Pull cables should be fitted in such a way that no kinks or "S" bends are formed which could cause a malfunction.

25.7.2. All plumbed-in extinguisher systems must be in the "ARMED" condition (capable of being operated without the removal of any disabling device) at all times when the vehicle is on the racetrack and at any post track session technical inspection.

- 25.7.3. Any plumbed-in extinguisher system found to be incapable of being operated will be the subject of a report to the Race Director and possible penalty.

26. DRIVER SAFETY SYSTEM

26.1. Driver's Equipment

Some safety equipment has had its homologation removed. Please review the FIA Technical Lists at <https://www.fia.com/regulation/category/761>.

Drivers must wear the following equipment during all on-track sessions:

26.1.1. A safety helmet which meets one of the following FIA-approved standards:

- Snell Foundation SA2010, SAH2010, SA2015, SA2020
 - Note: SA2010, SAH2010, and SA2015 helmets will not be accepted after Dec 31, 2023.
- SFI Foundation Inc., 31.1, 31.1A, 32.2A
- FIA 8860-2004, 8860-2010, 8860-2018

No helmet may be modified from its specification as manufactured, except in compliance with instructions approved by the manufacturer and the standards organization which certified the model concerned. Any other modification will render the helmet unacceptable.

26.1.2. Full-face helmets and shields must be worn by drivers of open cockpit cars and are strongly recommended for drivers of closed cockpit cars.

26.1.3. Helmet removal devices are recommended, such as Stand 21 Lid Lifter or Eject Helmet Remover system.

26.1.4. Drivers must use a Frontal Head Restraint device. The following specifications are accepted:

- FIA 8858-2002, 8858-2010
- SFI Foundation Inc., 38.1

26.1.5. Drivers must wear fire-resistant balaclavas. Fire-resistant helmet skirts are recommended. The following specifications are accepted:

- FIA 8856-2000, 8856-2018
- SFI Foundation Inc., 3.3

26.1.6. Single-layer suits are prohibited. Only multi-layer, one piece driving suits are permitted. They must be made of fire-resistant material accepted by ASN Canada, SCCA, or homologated by FIA, and must effectively cover the body including neck, ankles, and wrists. The following specifications are accepted:

- FIA 8856-2000, 8856-2018
- SFI Foundation Inc., 3.2A/5, 3.4/5

26.1.7. Fire-resistant underwear is required with double layer suits, but not required with three or more-layer suits unless the manufacturer of the suit so specifies. The following specifications are accepted:

- FIA 8856-2000, 8856-2018
- SFI Foundation Inc., 3.3

26.1.8. Socks made of fire-resistant material are mandatory. The following specifications are accepted:

- FIA 8856-2000, 8856-2018
- SFI Foundation Inc., 3.3

26.1.9. Shoes or gloves made of leather or any approved fire-resistant material containing no holes are mandatory. Gloves must have a layer of fire-resistant material next to the skin. The following specifications are accepted:

- FIA 8856-2000, 8856-2018
- SFI Foundation Inc., 3.3

- 26.1.10. Cars shall be equipped with, and the drivers shall utilize, seat belts and shoulder harness meeting the specifications of these Regulations. (See Section 27 of these Regulations.)
- 26.1.11. FIA homologated items shall no longer be valid after December 31 of the year of the expiration shown on the FIA label, or on December 31 of the calendar year 10 years after the manufacture date shown on the FIA label.

27. DRIVER RESTRAINT SYSTEM

- 27.1.1. All drivers in ASN Canada events must always utilize either a five, six, or seven-point restraint harness meeting SFI standard during any on-track session. The restraint system installation is subject to approval by the Chief Scrutineer.
- a. Restraint systems meeting SFI standards shall bear a dated SFI spec label. For older labels with the punched manufacturing date, the certification indicated by this label shall expire on Dec 31st of the 2nd year after the date indicated by the label. Starting in 2017 the labels will use a printed expiration date ("Valid Until"); the equipment is not valid after the date printed.
- b. All racing harnesses must have a clearly displayed manufacturers label in addition to its SFI label.**
- 27.1.2. All driver restraint equipment should be checked against the FIA Technical Lists for any equipment that has had its homologation removed. **Equipment that does not have a clearly identified manufacturer cannot be accepted, as it cannot be validated against the FIA Technical Lists.**
- 27.1.3. A minimum five-point system is required for use in automobiles where the driver is seated in an upright position, and consists of a lap belt, two shoulder straps and an anti-submarine strap, all of 50mm minimum width with load-spreading padding at pressure points.
- 27.1.4. A minimum six-point system is required for use in automobiles where the driver is seated in a semi-reclining position and consists of a lap belt, two shoulder straps, and two anti-submarine straps, all of 50mm minimum width with load-spreading padding at pressure points.
- 27.1.5. The material of all straps shall be nylon or dacron polyester and in new or perfect condition. The buckles must be of metal-to-metal quick-release type except in the case of leg straps of the six-point system where they attach to the seat belt or shoulder harness straps.
- 27.1.6. The shoulder harness shall be the over-the-shoulder type. There must be a single release common to the seat belt and shoulder harness.
- 27.1.7. The shoulder harness shall be mounted behind the driver and above a line drawn downward from the shoulder point at an angle of forty-degrees with the horizontal.
- 27.1.8. In cases where the driver is in a semi-reclining position, the shoulder harness shall be attached so that the angle between a line drawn through the driver's spine and the shoulder harness is forty-five degrees or greater.
- 27.1.9. Only separate shoulder straps are permitted. "H"-type configuration is allowed. "Y"-type shoulder straps are not allowed.
- 27.1.10. FHR specific shoulder straps are permitted, provided the restraint system was homologated with the straps, and only when used in conjunction with an FHR device.
- 27.1.11. The single anti-submarine strap of the five-point system shall be attached to the floor structure of the car similar to the shoulder harness mounting and have a metal-to-metal connection with the single release common to the seat belt and shoulder harness.
- 27.1.12. The double leg straps of the six-point system, or triple leg straps of a seven-point system may be attached to the floor as above for the five-point system or be attached to the seat belt so that the driver sits on them, passing them up between the legs and attaching either to the single release common to the seat belt and shoulder harness or attaching to the shoulder harness straps.
- It is also permissible for the leg straps to be secured at a point common to the seat belt attachment to the structure passing under the driver and up between the legs to the seat belt release or shoulder harness straps.
- 27.1.13. All straps must be free to run through intermediate loops or clamps/buckles.

The minimum acceptable bolts used in the mounting of all belts and harnesses are 3/8in SAE Grade 5. Where possible, seat belt, shoulder harness and anti-submarine straps should be mounted to the roll structure or frame of the car.

Where it is not possible to mount belts or straps directly to the roll structure or frame of the vehicle and they must be attached to a structural panel for example, the panel must be suitably reinforced in a workmanlike manner to prevent distortion under load. Steel reinforcing plates of adequate large area and thickness must be installed to prevent the belt attachment from pulling through the panel under load.

Bolting directly to the floor panels, etc., without adequate reinforcement is not acceptable.

27.1.14. Driver restraint systems be replaced as specified by the manufacturer or homologation specifications.

Shoulder harness arrangement...

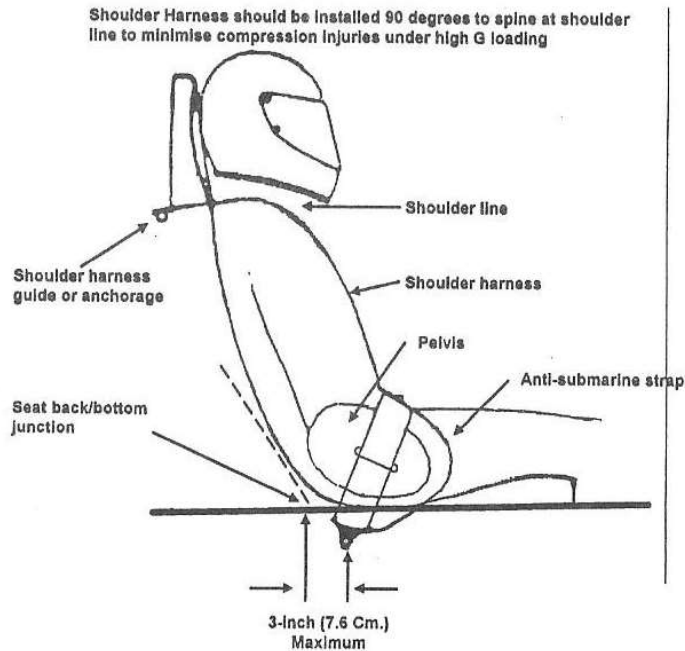

Shoulder harness top mounting...

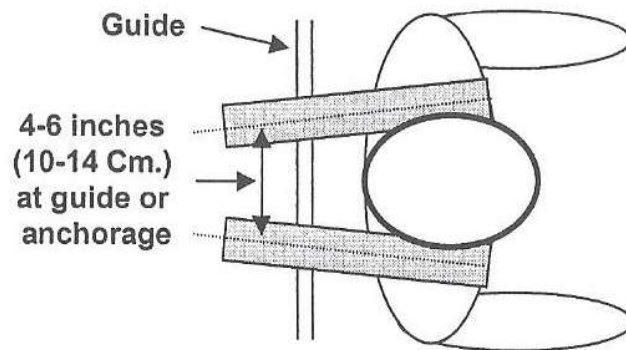

Safety harness mounting to chassis...

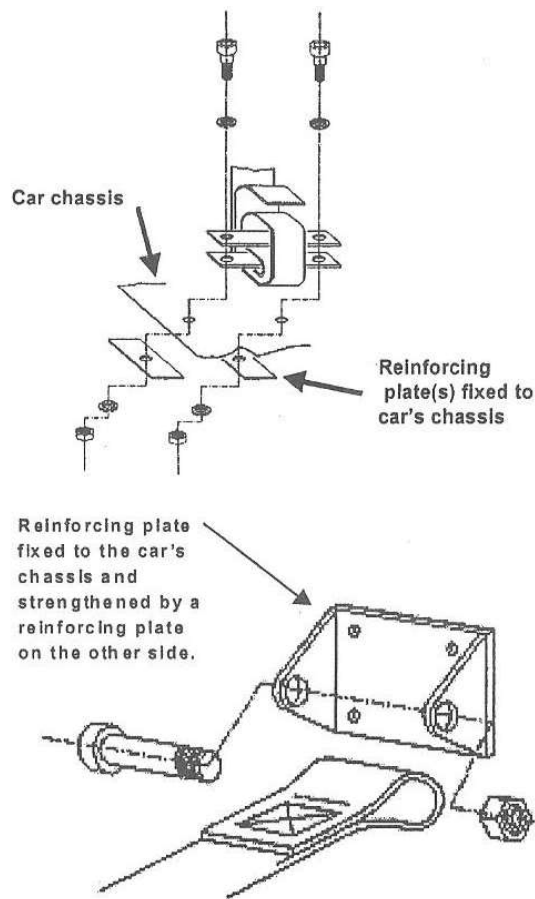

28. CLOSED WHEEL ROLL CAGE CONSTRUCTION

A Race Director, on recommendation by the Chief Scrutineer, may approve a roll cage installation specified by another sanctioning body provided the installation is no less robust than that described herein.

Series with homologated vehicles will use the roll cage structure as homologated. The acceptance of a homologated car by a Series means the roll cage is also approved.

28.1. General Description For Removable and Non-Removable Structures

28.1.1. Full width roll cages are required in all production-based Series cars.

Figure 1

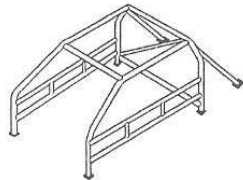

Figure 2

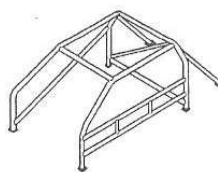

Figure 3

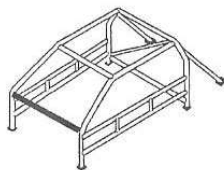
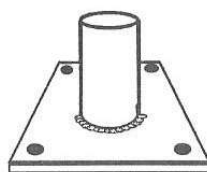

Figure 4



- 28.1.2. Non-flammable roll cage protective padding in the driver area where the driver/driver helmet could come in contact with the roll cage is mandatory.
- 28.1.3. Roll cages and braces, particularly removable roll cages, must be very carefully designed and constructed to be at least as strong as a permanent installation. If one tube fits inside another tube to facilitate removal, the telescoping removable portion must be at least eight inches in length, fit tightly and must bottom by design. At least two 3/8-inch (0.95 cm) diameter bolts must be used to secure each such joint.
- 28.1.4. Except for bolt-in roll cages, all joints shall be fully welded. All welding shall be of the highest possible quality with full penetration and shall be done to A.S.T.M. specifications for the materials used. Alloy steels shall be normalized after welding.
- 28.1.5. It is recommended that gussets be used at all welded joints.

28.2. Bolt Specification

- 28.2.1. Cars utilizing a bolt-in roll cage must use bolts meeting the following requirements:
 - a. The minimum acceptable bolts used in the securing of the roll cage is SAE Grade 5.
 - b. The minimum acceptable bolt diameter is 3/8 inch (0.95 cm).

28.3. Tubing Material and Sizes

Roll cages shall be of seamless or DOM mild steel tubing (SAE 1010, 1020, 1025) or equivalent, or alloy steel tubing (SAE 4125, 4130) or Docol R8® tubing. ERW tubing is not permitted. Minimum inch sizes and materials for front and main hoop tubes are as follows:

Vehicle Weight without driver	All Approved Materials
UP TO 1,500 lbs.	1.375 X 0.095
1,500 - 2,500 lbs.	1.500 X 0.095
OVER 2,500 lbs.	1.500 X.120 or 1.750 X 0.095

When alloy steel tubing is used, it must be normalized to relieve stress.

Provided proper manufactures recommend welding practices are carried out during the welding process, such as preheat and post heat in the case of 4125 and 4130, Docol R8® may be welded to other specified roll cage materials.

For roll cages built and registered prior to March 31, 2022, the following is also permitted:

Vehicle Weight without driver	Alloy Steel
UP TO 1,500 lbs.	1.375 X 0.080
1,500 - 2,500 lbs.	1.375 X 0.095
OVER 2,500 lbs.	1.500 X 0.095

28.4. Main Roll Hoop

The main roll hoop (behind the driver) must extend the full width of the driver/passenger compartment and must be as near the roof as is possible. It must incorporate a diagonal lateral brace to prevent lateral distortion of the hoop.

28.5. Front Roll Hoop

The front or side hoops must follow the line of the front pillars to the top of the windshield (as close to the roof as possible) then horizontally to the rear attachment point to the main hoop.

These two hoops are to be connected together by a tube over the top of the windshield.

Alternatively, a front hoop following the line of the front pillars and connected by horizontal bars to the main hoop on each side at the top.

28.6. Bracing

The main roll hoop must have two braces extending to the rear attaching to the frame or chassis.

Braces must be attached as near as possible to the top of the main hoop not more than six-inches below the top and at an included angle of at least 30-degrees.

28.7. Side Protection

Two horizontal side tubes connecting the front

28.7.1. Side protection is mandatory. Two (2) horizontal tubes bolted or welded to the front and rear main roll cage hoops on the driver's side as shown in Figure 1 below is preferred. Diagonal or horizontal bracing, whichever is most suitable for efficient ingress and egress, on the on-driver side, as shown in Figure 2 below is optional.

28.7.2. A single horizontal tube (Figure 3) joining the two front tubes, from side to side in the dash area, is recommended so long as the tube does not interfere with the driver's vision or operation of the vehicle.

28.7.3. The roll cage tubing must be attached to the chassis at six points. Two of these chassis attachment points can be at the rear suspension/strut towers.

28.7.4. Each tubing attachment point of the roll cage tubing must have a reinforcement plate (Figure 4) which must be no less than the thickness of the attached roll cage tube material and have an area of at least 20in² (129 cm²) and no greater than 30in² (194 cm²).

Figure 1

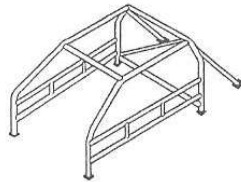

Figure 2

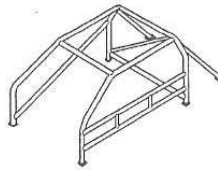

Figure 3

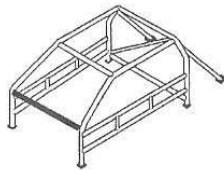
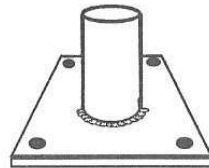

Figure 4



28.7.5. Non-flammable roll cage protective padding in the driver area where the driver/ driver helmet could come in contact with the roll cage is mandatory.

28.7.6. The Figure 4 tubing reinforcement plate, when used with a bolt-in roll cage, must be attached by a minimum of three (3) bolts to a second steel reinforcement plate which is welded to the chassis (see Figures below).

Mounting Point Details. Shown in the Figures below are alternative acceptable methods of attaching the roll cage tubing and reinforcement plates depending on the configuration of the vehicle surface attachment location.

For generally flat chassis surfaces:

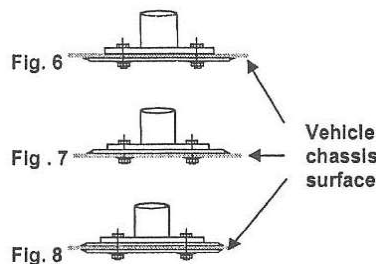

For uneven chassis surfaces:

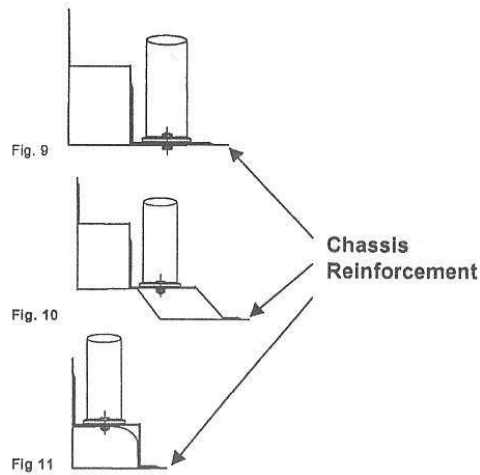

For all bolt-in roll cages, all roll cage tube chassis attachment plates as shown in Figures 9, 10 and 11 must use a minimum bolt size of 3/8 inch diameter (9.5 mm) with a minimum Grade 5 specification.

Mounting plates must not penetrate the fire wall at any point.

28.7.7. Roll cage tubing must have one (1) easily accessible inspection hole of 3/16 in. (4.8 mm) diameter in a non-critical area of the structure to aid in verifying wall thickness.

28.8. Mounting Plates

The mounting plate attachments to the structure of the car must be not less than 3/16 inch (0.5 cm) thick with a back-up plate of equal size and thickness on the opposite side of the panel with the plates through-bolted together using a minimum of three bolts per mounting plate.

28.9. Seat Back Mounting

Production-based OEM seat backs must be securely mounted and fastened. In order to provide a secure seat back fastener, a section of tubing equal to the roll bar shall be installed horizontally from the main hoop upright to the diagonal brace. This tube should be no higher than shoulder height.

Race seats should follow their manufacturers installation instructions.

28.10. Recommended tubing attachment methods:

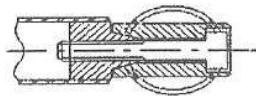

Drawing No 253-28

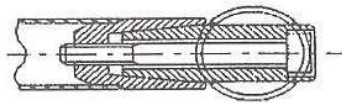

Drawing No 253-29

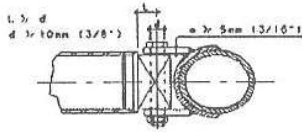

Drawing No 253-30

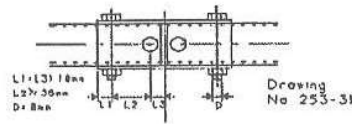

Drawing No 253-31

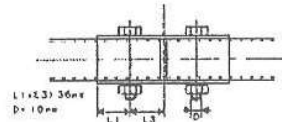

Drawing No 253-32

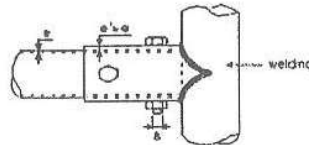

Drawing No 253-34

Dimensions in mm

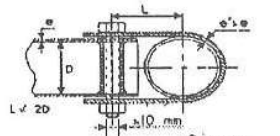

Drawing No 253-33

L must be minimum
The clamp width must
be of least 25 mm

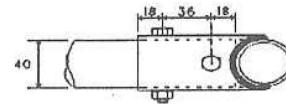

29. OPEN WHEEL ROLL PROTECTION INSTALLATION

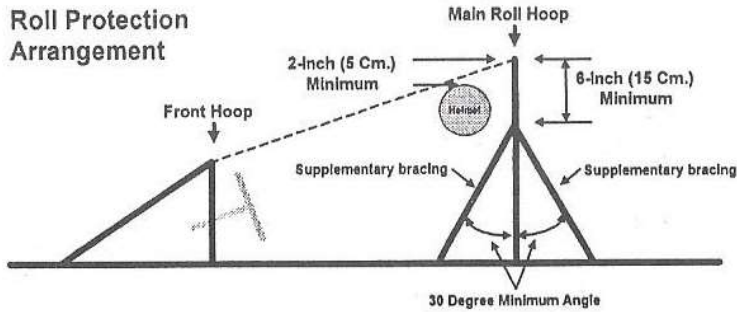

Alternative Main Roll Hoop Shapes

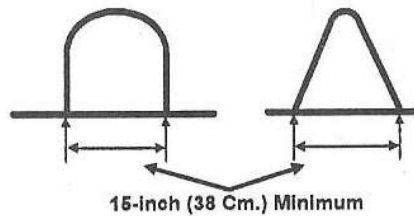

The main hoop shall be constructed of material that meets or exceeds the requirements in Section 28.3. The minimum bend radius shall be not less than three (3) times the tube diameter from the tube centreline. The main hoop shall not be less than two (2) inches above the driver's helmet when the driver is seated normally and restrained by seatbelt/shoulder harness.

A straight line drawn from the top of the main hoop to the top of the front hoop shall pass over the driver's helmet.

The vertical members of the main hoop shall not be less than 15 inches (38 cm) apart at their attachment to the chassis. If the hoop does not go to the belly pan, proper gussets and tube triangulation shall be used under its attachment.

On monocoque chassis the main hoop shall be welded to mounting plates that are not less than 0.080 inches (0.20 cm) thick. It is important that these plates be attached to the chassis in such a way as to spread the load over a wide area. There shall be a plate of equal thickness on the inside of the monocoque with solid rivets or bolts (5/16-inch -- 0.80 cm) through the non-ferrous material.

Front hoops must be no lower than the top of the steering wheel. It is recommended that the hoop extend to the belly pan. If not, it shall be attached to the chassis with gussets and triangulation in order to spread the loads.

In cars of full height (top of steering wheel) monocoque or composite construction, a steel plate, not less than 0.080 inches (0.20 cm) in thickness must be attached as a rub block.

29.1. Main Roll Hoop Bracing

The main hoop must have two forward braces extending from the hoop and attached to the frame, monocoque, or front hoop.

Braces must be attached as near as possible to the top of the hoop but must not be more than six (6) inches below the top and at an included angle of at least thirty (30) degrees.

If these braces do not extend to the front hoop, an additional brace or gusset 14 gauge (0.078 inches - 0.20 cm) minimum thickness) must be installed between the lower frame rail and the upper frame rail at the point of attachment of the forward hoop brace.

If these braces do not extend to the front hoop, an additional brace or gusset must be installed at the point of attachment to the main rear hoop or lower frame rail or other major frame member in such a manner as to reinforce the attachment point to help prevent collapse of the frame rail at the point of attachment.

These tubes shall be 1" x 0.080" minimum and gussets shall be 14 gauge (0.078 inches - 0.20 cm) minimum thickness.

29.2. Front Roll Hoop Bracing

The front hoop must have two (2) braces near its top extending forward to protect the driver's legs.

It is recommended that this bracing extend to the bulkhead in front of the driver's feet, but in any case, it must be integrated into the chassis to provide substantial support for the main front hoop.

Full width front hoop bracing must be the same diameter and wall thickness as the main hoop.

30. VIOLATION OF REGULATIONS

30.1. Assessment of Penalties

Any promoter, organizer, official, entrant, driver or other person committing a breach of these Regulations or those of a Series or event, or of any conditions attached to an organizing permit, or of any instructions to drivers, or of any special racetrack Regulations, may be penalized.

30.2. Breach of Regulations

In addition to any other offences, the following offences shall be deemed to be a breach of these Regulations:

- 30.2.1. Bribery or attempt to bribe anyone connected with the competition, and the acceptance of or offer to accept a bribe.
- 30.2.2. Any action having as its objective participation in the competition of a person or car known to be ineligible.
- 30.2.3. Any fraudulent proceeding or act prejudicial to the interests of the Series, ASN Canada, or of motorsport in general.
- 30.2.4. Any words, deeds, or writings that have caused moral injury or loss to the Series, ASN Canada, its bodies, its members, or its executive officers, and more generally on the interest of motorsports and on the values defended by ASN Canada.
- 30.2.5. Refusing to cooperate with, interfering with or obstructing the action of an official.
- 30.2.6. Any unsafe act or failure to take reasonable measures, thus resulting in an unsafe situation.
- 30.2.7. Failure to follow the instructions of the relevant officials for the safe and orderly conduct of the event.
- 30.2.8. Abusing another competitor or official.
- 30.2.9. Unsportsmanlike conduct.

30.2.10. Driving infractions as defined in these Regulations.

30.2.11. Any public incitement to violence or hatred.

30.3. Repeated Violations

30.3.1. Repeated breaches of these Regulations are subject to an increase in severity of the penalty imposed for each subsequent occurrence.

30.3.2. In cases of incidents that involve multiple violations, consecutive penalties may be imposed.

30.3.3. Combinations of penalties may be assessed.

31. PENALTIES

31.1. Reprimand

A reprimand may be imposed by the Steward(s). A reprimand against an ASN Canada licensed driver shall be noted in the driver's licence file, as shall be any or all other penalties.

31.2. Time Penalty

Time penalties in seconds or minutes and seconds may be imposed by the Steward(s) or Appeal Proceedings. "Stop-and-go", "Stop-and-hold", and "Drive-Through" penalties shall be considered to be time penalties and are not subject to appeal.

31.3. Distance Penalty

A penalty may be in the form of one or more laps. Competitors may be penalized by the Steward(s) or as a result of Appeal Proceedings.

31.4. Monetary Fine

31.4.1. Fines imposed must be paid within 72 hours after notification of the competitor. Any delay in making payment will entail suspension of competition privileges equal to the period during which a fine remains unpaid. All fines shall be remitted to the Series.

31.4.2. Failure to honour a cheque payable to the Series will result in suspension of the entrant's or driver's competition privileges until full payment of the fine, bank charges, and an additional service charge of \$50 has been paid.

31.5. Exclusion Penalty

Exclusion from participation may be imposed by the Steward(s) on an entrant, person, or car at any time.

31.6. Amendment of Placing

In those cases where a penalty of exclusion is imposed, the Steward(s) or Appeal Proceedings shall declare the resulting amendment to the placing and awards and shall decide whether the next competitor in order shall be advanced, and awards presented consistent with the revised finishing order.

31.7. Loss of Event Awards

Any entrant or driver who is excluded from any session or competition shall automatically forfeit all rights to awards in that session or competition.

31.8. Loss of Series Points

Loss of points earned by a competitor in a race, or accumulated in a Series, may be imposed by the Steward(s) or ASN Canada on the recommendation of the Steward(s).

31.9. Disciplinary Action

31.9.1. Participants who display a disregard or repeated disregard for Regulations, or who by their conduct display unsportsmanlike conduct are subject to disciplinary proceedings.

31.9.2. ASN Canada at its discretion may commence a disciplinary action at a competition.

31.9.3. The results of a Disciplinary Action are final, and any orders or penalties applied to a competitor are binding upon the parties.

31.10. Probation

- 31.10.1. Probation may be imposed by the Steward(s) or result from a Disciplinary Action or Appeal Proceedings.
- 31.10.2. Any additional penalties assessed during the probation period may be harsher.
- 31.10.3. ASN Canada will record any probation in a driver's file. Failure to comply with the terms of probation shall be reason for further penalties. ASN Canada may review any probation before its expiration.

31.11. Suspension of Privileges

- 31.11.1. Suspension of competition privileges may be imposed by ASN Canada on the recommendation of the Steward(s).
- 31.11.2. When a penalty of suspension is levied against a driver, the driver's competition licence must be immediately surrendered to ASN Canada. Delay in surrendering a licence as directed shall automatically result in the extension of the suspension by a period double the period of the delay.

31.12. Disqualification

- 31.12.1. A sentence of disqualification may be pronounced by the Steward(s) or ASN Canada.
- 31.12.2. A sentence of disqualification shall be pronounced for violation of Section 1.5.1c of these Regulations.

31.13. Publication of Penalties

Each Series and ASN Canada reserves the right to publicise a notice that it has penalized any person or organization and to state the reasons for the penalty. The persons or body referred to in the notice shall have no right of action against the Series, ASN Canada, or its officials, or against any person publishing or printing such notice, and may incur further penalties if such action is taken.

32. PROTESTS

32.1. The Right Of Protest

- 32.1.1. The right to protest lies solely with entrants and drivers who may consider themselves aggrieved by any decision, act or omission of a promoter, organizer, official, entrant, driver, or other person connected with any competition in which they are taking part, except that there shall be no right to protest against refusal of an entry, nor where otherwise expressly prohibited by these Regulations.
- 32.1.2. The onus is always on the entrant or driver, as the protestor, to establish the exact terms of the protest.
- 32.1.3. The right to protest shall be predicated only on a protest being well-founded. The Steward(s) shall review submitted protests and deem them well-founded or not.
- 32.1.4. A well-founded protest is defined as being reasonable, logical, based on relevant facts and supported by relevant evidence.

A fact is defined as something that can be proven, and evidence is defined as that which supports fact, logic, or reason.
- 32.1.5. Protests that are deficient in reason, logic, facts, or evidence may be deemed as not well-founded, and may be denied by the Steward(s) and the protest fee retained.
- 32.1.6. Hearsay, conjecture, and unsupported opinion may be considered vexatious. Vexatious is defined as: of little or no significance or importance, annoying, disturbing.
- 32.1.7. Protests that are deemed not well-founded, may also be vexatious and may be denied. In such instances the protest fee shall be retained, and further penalties may be applied.
- 32.1.8. Several competitors cannot lodge a joint protest.
- 32.1.9. A competitor wishing to protest more than one fellow competitor must lodge separate protests against each.
- 32.1.10. Drivers must remain at a competition and be easily contacted until any protest period relating to their competition has elapsed. No substitute representation is permitted.
- 32.1.11. Participants involved in a dispute or protest shall remain at the racetrack for the protest period, and for any reasonable period of time beyond as may be requested by the Steward(s).

Competitors who do not comply or cannot be easily contacted, are subject to judicial proceedings and penalties being applied in their absence. In such cases where penalties are applied, the possibility of appeal is forfeited. Any penalty applied shall remain in force.

32.1.12. Nothing in this Regulation shall affect or prejudice the right and duty of any official to take such action as deemed proper in any Circumstance, regardless of whether a protest has been lodged.

32.1.13. Decisions of any Judge of Fact are not subject to protest.

32.1.14. Decisions of the Steward(s) are not subject to protest, only an appeal.

32.1.15. It is the protestor's responsibility to understand and comply with these Protest procedures, and no claim for misunderstanding of any kind will be accepted.

32.2. Time Limits for Protests

The Steward(s) may extend a time limit but only for reasons of force majeure. Otherwise, for a protest to be considered it must be lodged with the Steward(s) in accordance with the following time schedule.

32.3. Eligibility of a Race Car

32.3.1. When the alleged ineligibility of a car, or a component of a car is apparent:

⇒ within 30 minutes after the end of the track session in which the alleged infraction is observed.

32.3.2. When the alleged ineligibility is not apparent, but it is alleged that the car is performing in a manner which suggests that it is ineligible:

⇒ within 30 minutes after the end of the track session in which the infraction is alleged to have occurred.

32.4. On-Track Conduct

A protest against any occurrence or irregularity while a practice, qualifying or race session was in progress:

⇒ within 30 minutes of the end of the track session in which the Infraction is alleged to have occurred.

32.5. Results

32.5.1. A protest concerning the results of a qualifying session:

⇒ within 30 minutes of the posting of the results of the session.

32.5.2. A protest concerning the provisional results of a race:

⇒ within 30 minutes of the posting of the provisional results of a race.

32.6. Video Evidence

32.6.1. If a competitor wishes to submit video of an incident in support of a protest, it shall be surrendered in its original, unedited format to the Steward(s):

⇒ within 30 minutes of the end of the session in which an incident is alleged to have occurred.

32.6.2. If a competitor wishes to submit video of an incident in defence of a protest, it shall be surrendered in its original, unedited format to the Steward(s):

⇒ within 30 minutes of the notification of the protest to the competitor.

32.6.3. Competitors submitting video shall provide at the same time the means to view the video or it shall not be allowed as evidence.

32.6.4. The Steward(s) reserve the right to preview video and decide on its acceptance as evidence. This decision shall be final and binding on all parties for the purposes of a protest.

32.6.5. Should a video be considered as valid evidence the competitor and/or entrant involved shall be allowed to view the video, only in the presence of the Steward(s) or a designate.

32.6.6. Once a video has been submitted as evidence it shall be impounded, whether accepted as evidence or not, until the time limit for giving Notice of Intention to Appeal has passed and such notice has not been given.

32.6.7. If a Notice of Intention to Appeal is given, the video, or a copy of the original created by a method approved by ASN Canada will be held by ASN Canada until the appeal hearing is conducted.

32.7. Protest of a Race Car

- 32.7.1. Only entrants and drivers entered in an event may protest the eligibility of another car.
- 32.7.2. In such cases the protestor shall clearly state the exact Regulation(s) alleged to have been violated and shall additionally stipulate the component(s) that are to be inspected.
- 32.7.3. The protestor shall be required to post a cash bond with the Series in the amount determined by the Steward(s), which amount shall be sufficient to cover the cost of any disassembly, inspection and reassembling by a qualified service technician.
- 32.7.4. Such Inspections shall be performed under the supervision of the Series or ASN Canada.
- 32.7.5. If a decision based on the inspection gives rise to an appeal by either party to the protest, the cash bond shall be retained until a final decision is made.
- 32.7.6. If the car is found not to conform to these Regulations or those of a Series, the cash bond shall be returned to the protestor and all inspection costs shall be borne by the entrant and/or driver of the inspected car.
- 32.7.7. If the car is found to be in conformity, the protestor will forfeit the cash bond to the Series, to cover the inspection costs involved. Any amount remaining after payment of costs will be returned to the protestor.
- 32.7.8. Failure of the entrant and/or driver of a protested car to allow inspection under the terms of this Regulation shall result in immediate exclusion and other penalties.
- 32.7.9. A protest under this Regulation may be reduced in scope by the protestor, but not added to, at the time the bond is set. Once a bond is posted, the stipulated inspections must be completed, except if entirely or partially withdrawn by the protestor before the inspection begins.
- 32.7.10. If a protest under this Regulation is withdrawn completely by the protestor prior to the commencement of the inspection, the Steward(s) shall return the cash bond to the protestor less an amount to be determined by the Steward(s), but in no case shall the retained amount be less than \$250.

32.8. Lodging a Protest

- 32.8.1. Every protest shall be made in writing, and must:
 - a. Specify which part(s) of these Regulations, Series Regulations or Event Supplementary Regulations considered to have been violated and by whom,
 - b. Provide names of witnesses, if any,
 - c. Provide video evidence if involved,
 - d. Be signed by the entrant or driver making the protest,
 - e. Be accompanied by a protest fee of \$500 payable to the Series.
 - f. Be delivered to the Race Director and addressed to the Steward(s) within the time limit specified within these Regulations.

32.9. Hearing of a Protest

- 32.9.1. The Steward(s) shall hear all protests. All parties concerned shall be given notice of the time and location of the hearing.
- 32.9.2. The Steward(s) shall determine if the protest was submitted in full accordance with these Regulations. Failure of the protestor to comply with all these conditions shall result in the return of the protest without hearing and the retention of the protest fee by the Series.
- 32.9.3. The onus is always on the protestor to properly present a protest, and no claim based on lack of knowledge of these, or Series or Event Supplementary Regulations shall be allowed.
- 32.9.4. Protestors at a hearing shall themselves (or with the assistance of a designated translator if language difficulties exist) state their case in person and are entitled to call witnesses and shall be responsible for the prompt availability of any witnesses called.

Should a protestor designate a translator for purposes of stating or arguing a protest, the words of the translator shall be deemed to be those of the protestor.

32.9.5. In the absence, or undue delay in attendance, of any party to a protest, judgement may proceed by default.

32.10. Distribution of Awards

Excepting any post-race victory award presentations which are unofficial, distribution of awards shall not commence until after the period for protests has elapsed. When a protest which would affect distribution of awards has been lodged, distribution shall be withheld pending the decision of a protest or appeal hearing. During this time the results of the competition shall be considered provisional.

32.11. Judgement from a Protest Hearing

All parties concerned shall be bound by the decision given, subject only to the Appeal Proceedings as provided in these Regulations.

32.12. Protest Fees

32.12.1. The Steward(s) shall determine the disposition of all fees as follows:

- a. In all cases a minimum of \$100 of a protest fee will be retained by the Series.
- b. If the protest is deemed to be not well-founded and/or vexatious, the entire fee will be retained by the Series.

32.12.2. If the protest is deemed vexatious the protestor shall be deemed guilty of a breach of these Regulations, shall forfeit the protest fee, and may be further penalized for this breach.

32.13. Publication of Judgements

The Series and ASN Canada shall have the right to publish or cause to be published a judgement of a protest and to state the names of all parties involved. The persons or bodies referred to in such a notice shall have no right of action against the Series or ASN Canada or against anyone printing or publishing said notice.

33. APPEALS

33.1. Request for an Appeal

33.1.1. Except where excluded in these Regulations, an entrant or driver may submit a request for an appeal of a decision that was rendered by the Steward(s). The appellant shall have the right to appeal only if they were the addressee of a Stewards' decision or if they were individually affected by such a decision.

33.1.2. A Request for an Appeal does not mean the Appeal will be allowed automatically.

33.1.3. Appeal proceedings of ASN Canada are designed to expedite sporting disputes in a timely and efficient manner and do not necessarily follow practices or formalities normally associated with those of the legal profession.

33.1.4. It is the appellant's responsibility to understand and comply with these Appeal procedures, and no claim for misunderstanding of any kind will be accepted.

33.2. Grounds for Appeal Requests

33.2.1. The grounds for a Request for an Appeal are any of the following allegations:

- a. The Steward(s) has dealt with the case using improper procedures.
- b. New substantial evidence and/or expert testimony relating to the case that could not have been readily available at the time of the application of the original decision by the Steward(s).

33.2.2. An Appeal will not be granted for a repeat presentation of the original protest. This will be determined only by ASN Canada.

33.3. Time Limit

33.3.1. Notice of the Intention to submit a Request for an Appeal shall be given to the Steward(s) within 1 hour of the verbal announcement of a Stewards decision and shall be accompanied by payment of \$1000.

33.3.2. A Request for an Appeal, signed by the appellant, must be submitted in a clear and legible form otherwise it may be denied without further action.

It is to be submitted to the ASN Canada office where it must be received within 72 hours after the submission to the Steward(s) of the Notice of Intention to submit a Request for an Appeal Hearing.

33.3.3. A Request for an Appeal may be withdrawn with the agreement of ASN Canada. The appeal fee shall be retained by ASN Canada.

33.4. Effect of Requesting an Appeal

Notice of Request for an Appeal shall not affect the validity of enforcement of any decision, penalty or sentence appealed against.

The Steward(s), if notified of intention to submit a Request for an Appeal, may permit a competitor to continue to participate in a competition if the matter arises during the course of an event.

This decision itself is not appealable, and in any event the Steward(s) shall order awards which may be affected by the outcome of the appeal to be withheld pending the outcome of a Request for an Appeal.

Penalties subject to an appeal shall be suspended except in the cases of immediate safety issues including breaches of alcohol or substance abuse regulations, time penalties as defined in Section 31.2, or in cases where a further breach is committed justifying the Disqualification of the same competitor, or if the appeal is received outside of the applicable deadline.

33.5. Required Submissions

33.5.1. A Request for an Appeal shall only be submitted **to ASN Canada** in person, by email, by mail, courier, or fax.

**200 circuit Gilles-Villeneuve,
Montréal, Québec, Canada, H3C 1A9
Phone: (514) 350-8203
info@asnCanada.ca**

33.5.2. A Request for an Appeal must contain sufficient information to allow ASN Canada to determine how a dispute will be managed, and whether formal Appeal Proceedings will take place. Failure of the appellant to provide sufficient information will result in the rejection of the appeal without a hearing and forfeiture of the appeal fee.

33.5.3. A Request for an Appeal shall specify in full:

- a. The grounds for claiming that the Steward(s) acted improperly, clearly indicating which part(s) of any Regulations are considered to have been enforced in a manner that was not fair or equitable to the appellant.
- b. A complete description of any new evidence and/or expert testimony and how it may affect the original protest decision.
- c. A list of witnesses that the appellant may wish to call, a description of their involvement in the incident in question, and the general nature of their testimony.
- d. The Request for an Appeal shall bear the signature of the appellant, or an authorized representative of the appellant accompanied by a letter authorizing the representative to act on behalf of the appellant and shall include the address to which communications should be sent with a telephone number, and a fax number if available.

33.5.4. ASN Canada reserves the right to preview any video submitted and decide on its acceptance as evidence. This decision shall be final.

33.6. Decision to Grant an Appeal

33.6.1. ASN Canada alone will decide if a Request for an Appeal is well-founded. Should an appeal not be granted, the appeal fee will be retained by ASN Canada.

33.6.2. ASN Canada reserves the right to settle any dispute that may be referred to in a Request for Appeal without submitting the case to Appeal Proceedings.

33.6.3. Should ASN Canada deem that a Request for an Appeal is vexatious in nature the entire appeal fee will be forfeited and further penalties may be applied.

33.6.4. Decisions made under this Regulation shall be final and binding upon the appellant and not subject to further action.

33.7. Appeal Proceedings

33.7.1. An appeal may be handled administratively by ASN Canada without a formal hearing.

When a formal hearing is deemed necessary by ASN Canada, an Appeal Chairperson will be appointed by ASN Canada. The Appeal Chairperson will attempt to convene and hear an appeal no later than 1 week after an ASN Canada decision to grant an appeal hearing.

Notice to the appellant indicating the time and place for the hearing will be given. It is incumbent upon the appellant to assemble any witnesses at the appointed place and time.

- 33.7.2. At a formal Appeal Hearing the appellant may present evidence and may call witnesses. The appellant may have counsel present with the permission of the Appeal Chairperson but must always present their case personally.

An appellant may submit the case to the Appeal Chairperson entirely in writing without personal appearance.

- 33.7.3. The Appeal Chairperson may hear evidence and witnesses in any manner deemed by the Chairperson to be appropriate, relevant, or necessary.

33.8. Provision for Expedited Appeal

- 33.8.1. ASN Canada may arrange at its discretion the alteration of the appeal process so as to provide an expedited appeal.

- 33.8.2. An expedited appeal may be dealt with by ASN Canada immediately after a decision of a Steward(s) has been given, and a Notice of Intention to submit a Request for an Appeal has been given to the Steward(s) by the appellant.

- 33.8.3. The results of such an expedited appeal shall be final and binding on all parties.

33.9. Jurisdiction of Appeal Proceedings

ASN Canada appointees to Appeal Proceedings shall not participate or sit in judgement if they have taken part as competitors, officials, organizers, promoters, or sponsors in the competition which involves the subject of the appeal, or who have been directly involved in the matter under consideration.

33.10. Judgement of Appeal Proceedings

After considering the material deemed relevant to reach a decision, an Appeal Chairperson shall prepare a written judgement. An existing penalty may be nullified, mitigated, affirmed, increased, or a different penalty imposed. A competition cannot be re-run, nor an event schedule revised.

- If the Appeal is found to be not well-founded, vexatious or without merit, the entire appeal fee may be retained.
- If the Appeal is judged to be partially founded, the deposit may be returned in part except for a \$200 administration fee.
- If the Appeal is upheld, the Appeal fee may be returned in full.

33.11. Judgement is Final

Appeal judgements constitute the final court of appeal to settle any dispute arising out of or in connection with a Series competition and no further action may be taken by the appellant.

33.12. Publication of Judgements

ASN Canada shall have the right to publish or cause to be published a judgement of an Appeal and to state the names of all parties involved. The persons or bodies referred to in such a notice shall have no right of action against ASN Canada or against anyone printing or publishing said notice.

33.13. Conduct After Judgement

Any participant who, subsequent to an Appeal judgment, discredits or attempts to discredit the judgment shall be subject to disciplinary action.